

INVERTEK® WINDSTAR SERIES

WS-120C
Installation and Operation Manual

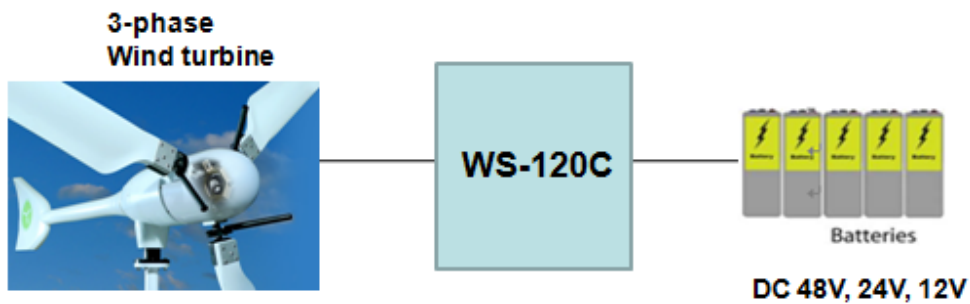

Wind Charger



CONTENTS

Chapter 1 WindStar Description.....	1-1
1.1 Versions and Ratings	1-1
1.2 Operating	1-1
1.3 Adjustability	1-1
1.4 General Use.....	1-2
Chapter 2 WindStar Installation.....	2-1
2.1 General Information	2-1
2.2 Installation Overview.....	2-1
2.3 Control Terminal Connection.....	2-2
2.4 Installation Steps	2-2
Chapter 3 Front Cover of WindStar Operation	3-1
3.1 LED Status Indicators	3-2
3.2 Charge Control or Diversion Control Mode Indications	3-2
3.3 Equalization Mode Indication	3-2
3.4 Fault Mode Indication	3-3
3.5 LCD Meter Displays	3-3
Chapter 4 Battery Charging	4-1
4.1 Battery Charging	4-1
4.2 Standard Battery Charging Programs.....	4-1
Chapter 5 Diversion Charge Control.....	5-1
5.1 Diversion Charge Control	5-1
5.2 Diversion Current Ratings	5-1
5.3 Standard Diversion Battery Charging Programs	5-1
5.4 Selecting the Diversion Load.....	5-2
5.5 Capacity	5-2
Chapter 6 Trouble Shooting	6-1
Chapter 7 Battery Information.....	7-1

Chapter 1 WindStar Description

The WindStar is a technically advanced wind charger. It includes DC diversion charge control, so user has to install the diversion load with it.

The manual will help you to become familiar with the WindStar's features and capabilities. Some of these follow:

- LCD meter with easy to read messages.
- DIP switch to set up the wind charger for its intended use. All major functions can be set with DIP switches.
- Rated for 12, 24, 48 voltage systems and 120 amps current.
- Eight standard charging with DIP switches.
- Continuous self-testing with fault notification
- LED indications and pushbutton functions.

1.1 Versions and Ratings

WindStar-120 (WS-120C):

Rated for maximum 120 amps continuous current

Rated for 12, 24, 48 Voltage DC systems

※Diversion Load (optional)

1.2 Operating

The WindStar will manage battery charging by 3-phase wind turbine from the battery to a dedicated diversion load.

1.3 Adjustability

Eight DIP switches permit the following parameters to be adjusted at the installation site:

DIP switch	Wind Charger	
1	Always in the OFF position	
2	3	Select Battery Voltage
OFF	OFF	48V system
ON	OFF	24V system
OFF	ON	12V system
4~6	Standard battery charging programs	
7 (OFF)	Manual Equalization	
(ON)	Auto Equalization	
8	Always in the OFF position	

1.4 General Use

- The WindStar is configured for negative ground systems. There are no parts in the wind charger's negative leg. The enclosure can be grounded using the ground terminal in the wiring compartment.
- There are fuses or mechanical parts inside the WindStar to reset or change.
- The WindStar is rated for indoor use. The wind charger is protected by conformal coated circuit boards, stainless steel hardware, anodized aluminum, and a powder coated enclosure, but it is not rated for corrosive environments or water entry.
- The construction of the WindStar is 100% solid state.
- With bulk charging, absorption, float and equalization stages.
- The WindStar will accurately measure time over long intervals to manage events such as automatic equalizations or battery service notification.
- LED's, a pushbutton, and LCD meters provide both status information and various manual operations.

Chapter 2 WindStar Installation

The installation instructions describe wind battery charging.

2.1 General Information

The mounting location is important to the performance and operating life of the wind charger. The environment must be dry and protected as noted below. The wind charger may be installed in a ventilated enclosure with sealed batteries, but never in a sealed battery enclosure or with vented batteries.

2.2 Installation Overview

The installation is straightforward, but it is important that each step is done correctly and safely. A mistake can lead to dangerous voltage and current levels. Be sure to carefully follow each instruction in Section 2.3 and observe all cautions and warnings.

The following diagrams provide an overview of the connections and the proper order:

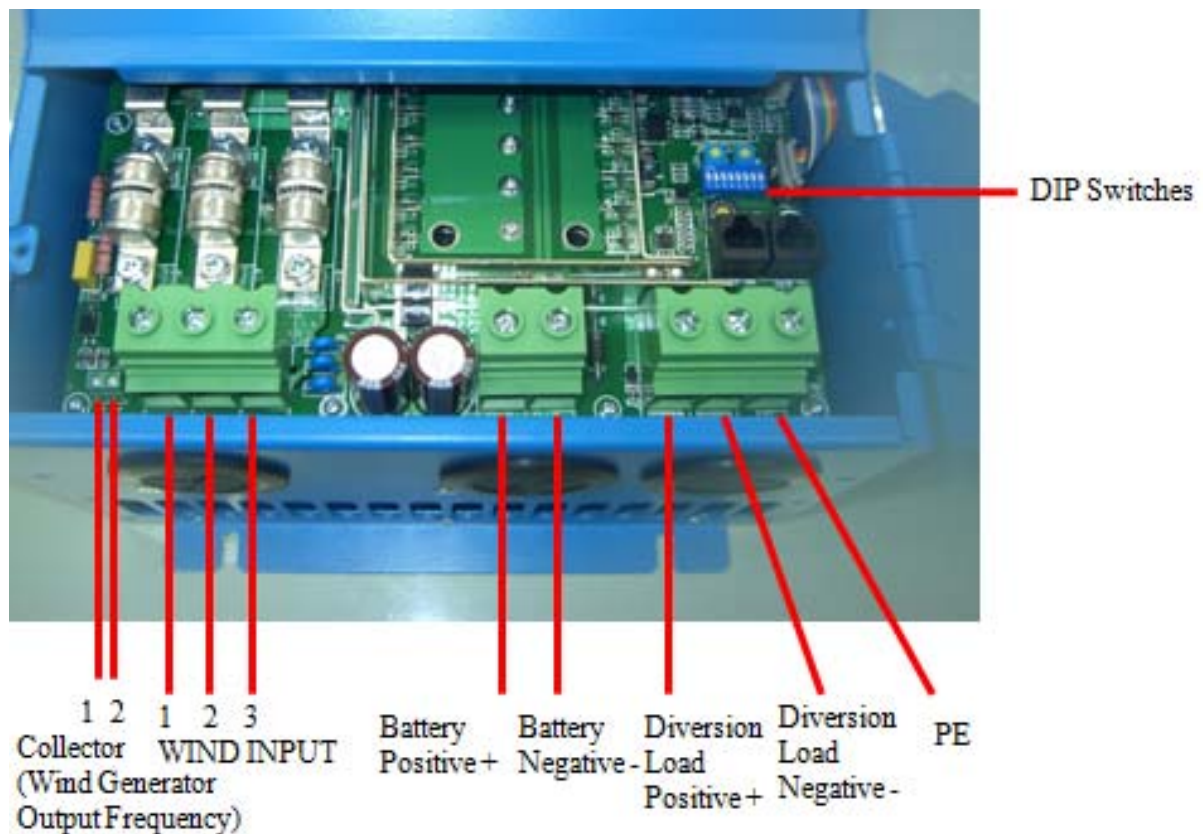

2.3 Control Terminal Connection

Name	Description
Collector 1	Positive connection of the Wind Generator Output Frequency
Collector 2	Negative connection of the Wind Generator Output Frequency
WIND INPUT 1	Connecting terminal for Wind Turbine
WIND INPUT 2	Connecting terminal for Wind Turbine
WIND INPUT 3	Connecting terminal for Wind Turbine
Battery +	Battery cable Positive connection
Battery —	Battery cable Negative connection
DIVERSION LOAD +	Connecting terminal for Diversion load
DIVERSION LOAD —	Connecting terminal for Diversion load
PE	Connecting terminal for Ground
Dip Switch 1	Always in the OFF position
Dip Switch 2, 3	Selection of battery voltage for 12V or 24V or 48V system
Dip Switch 4, 5, 6	Battery charging algorithm
Dip Switch 7	Auto or Manual Equalization
Dip Switch 8	Always in the OFF position

※Install the counter with Collector 1 and Collector 2 by yourself and then you will know the wind speed of the Wind Turbine (rpm). The output of the Collector 1 and 2 is the Wind Generator Output Frequency.

2.4 Installation Steps

The WindStar wind charger must be installed properly and in accordance with the local and national electrical codes. It is also important that the installation be done safely, correctly and completely to realize all the benefits that the WindStar can provide for your wind system.

Before starting the installation, review these safety notes:

- Do not exceed a battery voltage of 48V (nominal). Do not use a battery less than 12V.
- Charge only 12, 24, or 48 volt lead-acid batteries when using the standard battery charging programs or NI-CAD batteries when DIP switch number 4~6 is ON position in the WindStar.
- Verify the nominal charging voltage is the same as the nominal battery voltage.
- Do not install a WindStar in a sealed compartment with batteries.
- Never open the WindStar access cover unless both the wind turbine and battery power has been disconnected.
- Never allow the Wind Turbine to be connected to the WindStar with the battery and Diversion load disconnected. This can be a dangerous condition with high voltage present at the terminals.

2.4.1 Mounting

Unit: mm

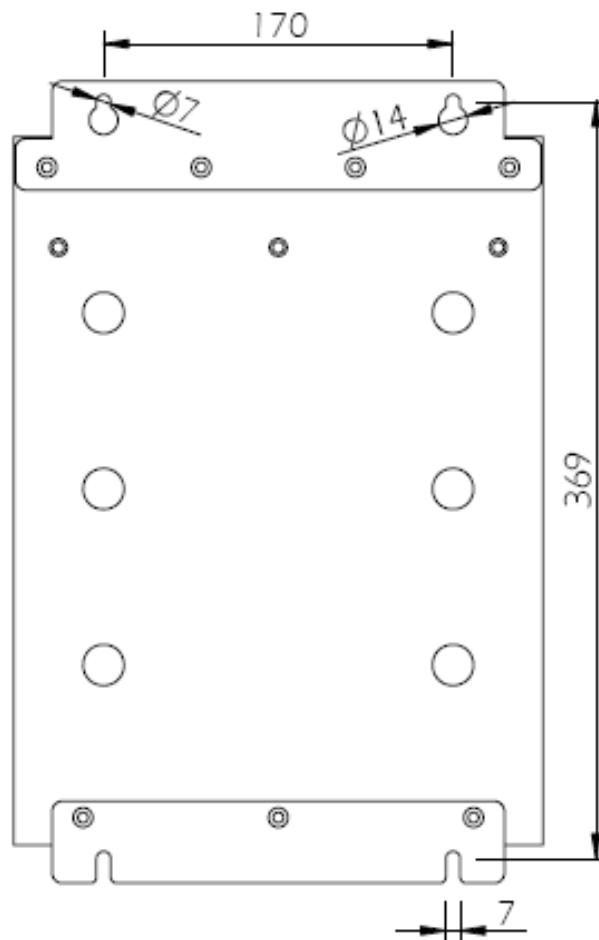

Mounting Dimensions

- Locate the WindStar on a wall protected from direct sun, high temperatures, and water. Do not install in a confined area where battery gasses can accumulate.
- When mounting the WindStar, make sure the air flow around the controller and heat sink is not obstructed. There should be open space above and below the heat sink, and at least 75 mm (3 inches) clearance around the heat sink to allow free air flow for cooling.
- Before starting the installation, place the WindStar on the wall where it will be mounted and determine where the wires will enter the controller.

Unit: mm

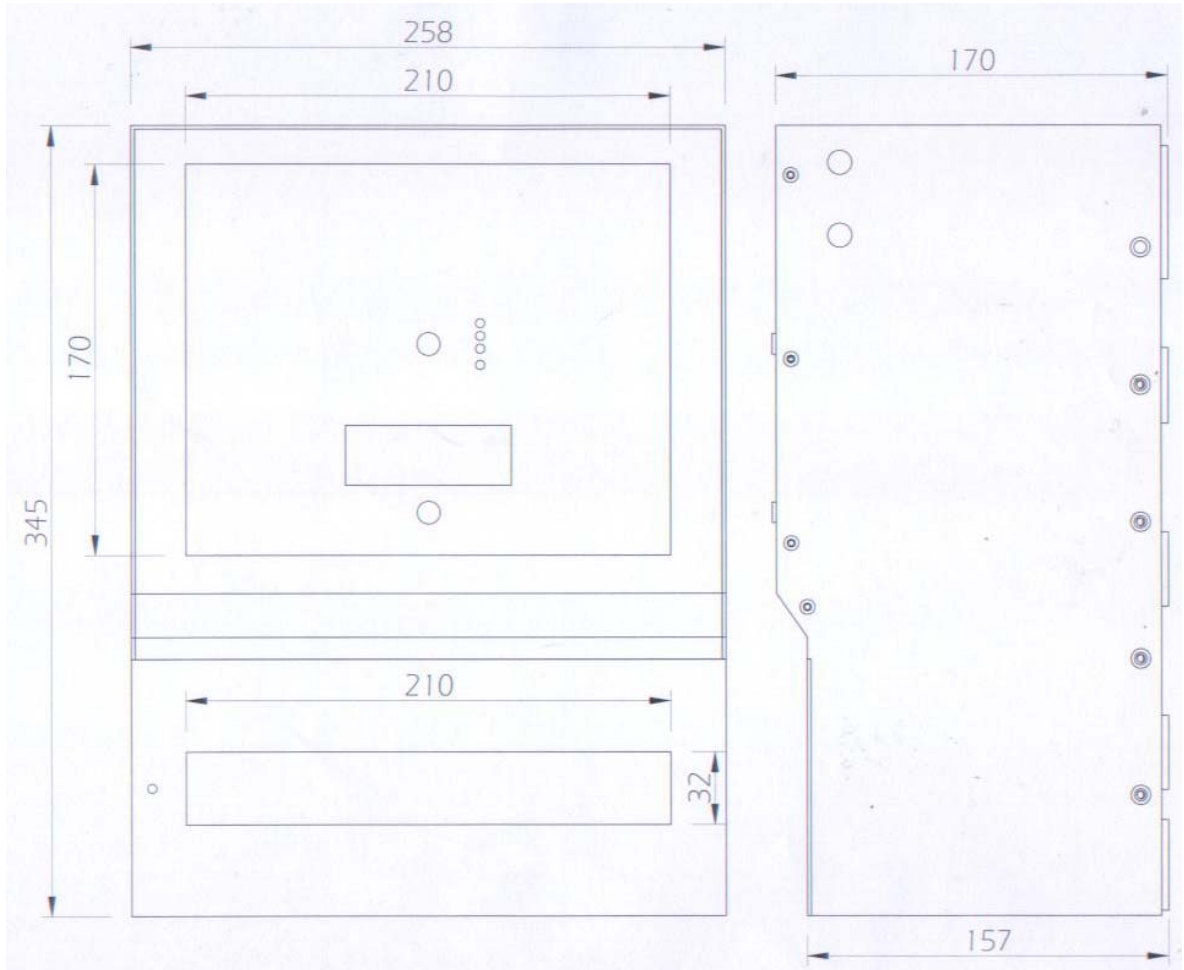

2.4.2 Diversion Charge Control DIP Switch Settings

The 8 DIP switches are located on the top of the PE terminal. Each switch is numbered. The wind battery charging functions that can be adjusted with the DIP switches follow:

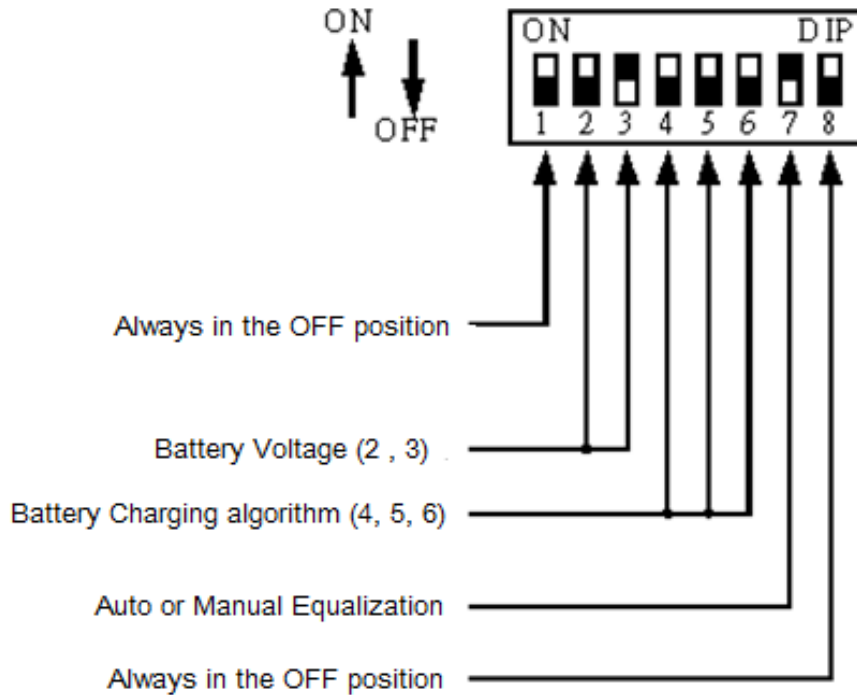

DIP Switch Functions

※ As shown in the diagram, all the positions are in the “OFF” position except switch number 3 and 7 which are in the “ON” position.

NOTE: The DIP switches should be changed only when there is no power to the wind charger. Turn off disconnect switches and remove all power to the wind charger before changing a DIP switch. A fault will be indicated if a switch is changed while the wind charger is powered.

CAUTION 1: The WindStar is shipped with all the switches in the “OFF” position. Each switch position must be confirmed during installation. A wrong setting could cause damage to the battery or other system components.

CAUTION 2: To change a switch from OFF to ON, slide the switch up toward the top of the wind charger. Make sure each switch is fully in the ON or OFF position.

CAUTION 3: DIP Switch Number 1 and Number 8 are always in the OFF position.

DIP Switch Number 1 and Number 8: Always in the OFF position

DIP Switch Number 2, 3-System voltage

Switch 2	Switch 3	System Voltage
OFF	OFF	48V system
ON	OFF	24V system
OFF	ON	12V system

DIP Switch Number 4, 5, 6-Battery charging algorithm

DIPSW-4	DIP SW-5	DIP SW-6	Bulk voltage	Float voltage	Equalize Voltage	Equalize Time (hours)	Equalize Interval (days)
OFF	OFF	OFF	14.0V	13.4V	None	-	-
OFF	OFF	ON	14.1V	13.4V	14.2V	1	28
OFF	ON	OFF	14.3V	13.4V	14.4V	2	28
OFF	ON	ON	14.4V	13.4V	15.1V	3	28
ON	OFF	OFF	14.6V	13.4V	15.3V	3	28
ON	OFF	ON	14.8V	13.4V	15.3V	3	28
ON	ON	OFF	15.0V	13.4V	15.3V	3	14
ON	ON	ON	16.0V	14.5V	-	-	-

Select one of the 7 standard battery charging algorithms, or select NiCad to determine the charging of the battery.

- ※ The above setting voltage value is in the condition of 12V system. The voltage will be twice of above values in the 24V system and it will be four times of above values in the 48V system.
- ※ Refer to section 7.0 of the manual for battery charging information.
- ※ The 7 standard charging algorithms above are described in section 4.2-standard battery charging programs.

DIP Switch Number 7 (ON): Auto Equalization;
 DIP Switch Number 7 (OFF): Manual Equalization

2.4.3 Finish Installation

Inspect for tools and loose wires that may have been left inside the enclosure.
 Check the power conductors to make sure they are located in the lower part of the wiring compartment and will not interfere with the cover and the LCD meter assembly.

NOTE: If the power conductors are bent upwards and touch the LCD meter assembly, pressing the cover down on the wires can damage the meter.

- Carefully place the cover back on the wind charger and install the one cover screw.
- Closely observe the system behavior and battery charging for 2 to 4 weeks to confirm the installation is correct and the system is operating as expected.

Chapter 3 Front Cover of WindStar Operation

There are 4 LEDs, 1 LCD Meter and 2 pushbuttons on WindStar front cover. The details are described as follows:

WS-120C Display Panel

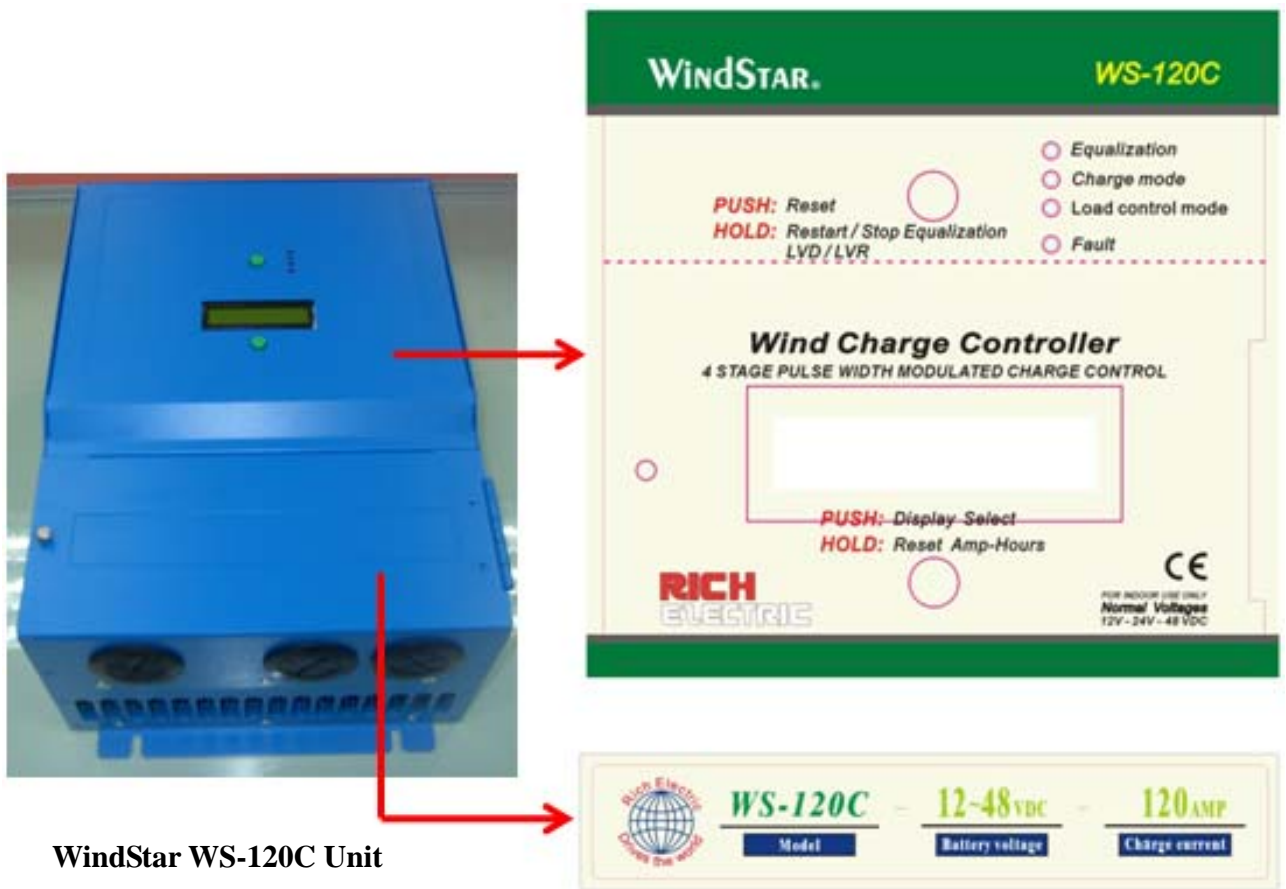

3.1 LED Status Indicators

Four LED indicate operating status of the wind charger. When the wind charger works, the charge mode (green) LED will blink. The Load Control Mode (red) LED is no function. When battery equalization is in process, the Equalization (orange) LED is blinking. A red LED solid or blinking indicates a fault condition.

3.2 Charge Control or Diversion Control Mode Indications

“Charge Mode LED” Solid Green:

The battery is being charged in the FLOAT stage. The status LED remains ON solid unless the batteries drop below the float voltage setting for an accumulative period of one hour. This allows the user to confirm that the system reached the float stage during the charging process when checked at the end of the day. Reaching the float stage frequently is a good indication of proper system operation and will maximize battery life and performance.

“Charge Mode LED” Blinking Green:

The wind charger is CHARGE CONTROL or DIVERSION CONTROL Mode and the battery is not fully charged. AS the battery voltage approaches the BULK setting, the status LED will blink green several times (up to five) and then pause, indicating the battery voltage is approaching the BULK setting and provides an indication of the battery condition. Refer to the table 1 to determine the battery voltage.

NOTE: A single green flash indicates the battery is below the bulk voltage setting. It does NOT indicate the batteries are charging.

Battery Voltage (Using LED Status Indicator)			
LED Status	Green LED (Charge/Diversion Mode)		
Always ON	Battery at FLOAT setting		
5 Blinks	Battery at BULK setting		
Bulk Setting Minus (-)			
4 Blinks	0.25 VDC	0.50 VDC	1.00 VDC
3 Blinks	0.50 VDC	1.00 VDC	2.00 VDC
2 Blinks	0.75 VDC	1.50 VDC	3.00 VDC
1 Blinks	> 0.75 VDC Below Bulk	> 1.50 VDC Below Bulk	> 3.00 VDC Below Bulk
DC Voltage	12 Volts	24 Volts	48 Volts

Table 1 Battery Voltage LED Indication

3.3 Equalization Mode Indication

“Equalization LED” Blinking Orange:

The wind charger is in the Equalization Mode. It will automatically stop the equalization process after accumulating setting Equalize Time of operation at Equalize Voltage above the BULK setting. The user can stop the equalization process at any time by pressing the reset pushbutton until the status LED stops.

3.4 Fault Mode Indication

Solid Red:

The wind charger detects an over-current condition and the battery is disconnected. The wind charger will try to automatically restart the battery after a 10 second delay. If the wind charger will not restart, turn off all batteries and press the reset pushbutton. A delay up to five seconds may occur before the wind charger attempts to restart after pressing the reset pushbutton. The data exchange between CPU and the display panel can be detected a fault by the wind charger by showing alarm CPF00.

3.5 LCD Meter Displays

These displays include a two-line, 32-characters LCD and Four status LED indicator.

The LCD provides the following information:

- Wind Turbine or DC Load press-through current: 0~120 amps DC
- Battery Voltage: 10.5 to 80 Volts DC
- Watts: 0 to 6000 Watts (Volts time Amps)
- Amp-hours: 0 to 655536Ah; can be reset to 0
- Totalizing amp-hours: 0 to 65536 Ah; reset to 0 when power is disconnected
- Battery charging status
- Display of BULK and FLOAT voltage setting value
- Display of Equalization Voltage, Equalization Time and Equalization Interval
- Display of heatsink temperature
- Fault Messages

3.5.1 LCD Displays Flow

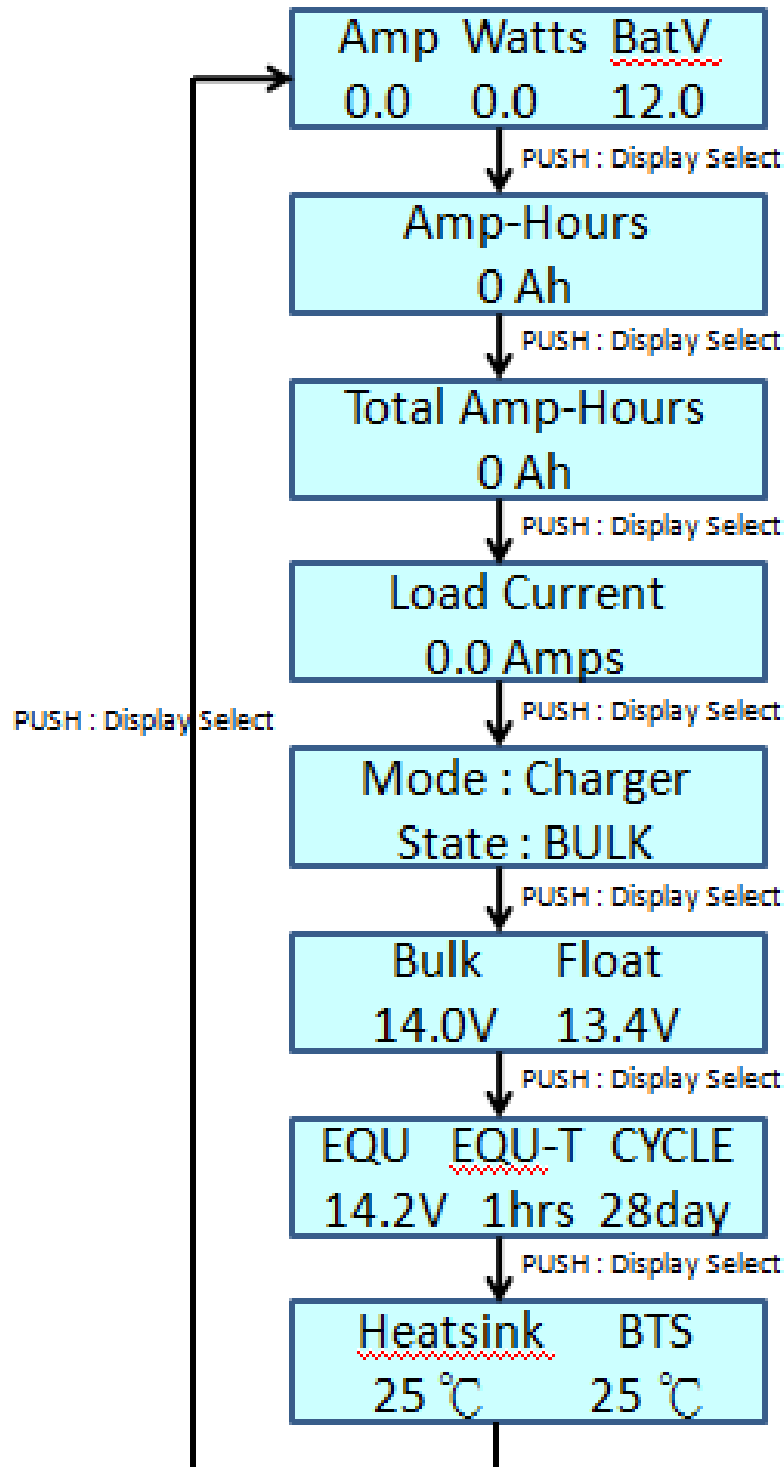

3.5.2 Fault Messages

The LCD displays might have the following fault messages when WindStar stops operating.

Refer to their description and causes listed as below in order to remove the faults.

Display	Description	Cause Details
Alarm : OC Over Current	Over Current	The current exceeds 150% of rated current.
Alarm : OT Over Temperature	Heatsink Over Temperature	Heatsink temperature exceeds 90°C.
Alarm : CPF00 Link Master Err	Display Panel Error	The CPU is not able to exchange data with the display panel.

Chapter 4 Battery Charging

4.1 Battery Charging

Selecting the best method for charging your battery together with a good maintenance program will ensure a healthy battery and long service life. Although the WindStar's battery charging is fully automatic, the following information is important to know for getting the best performance from your WindStar wind charger and battery.

4.1.1 Four Stages of Charging

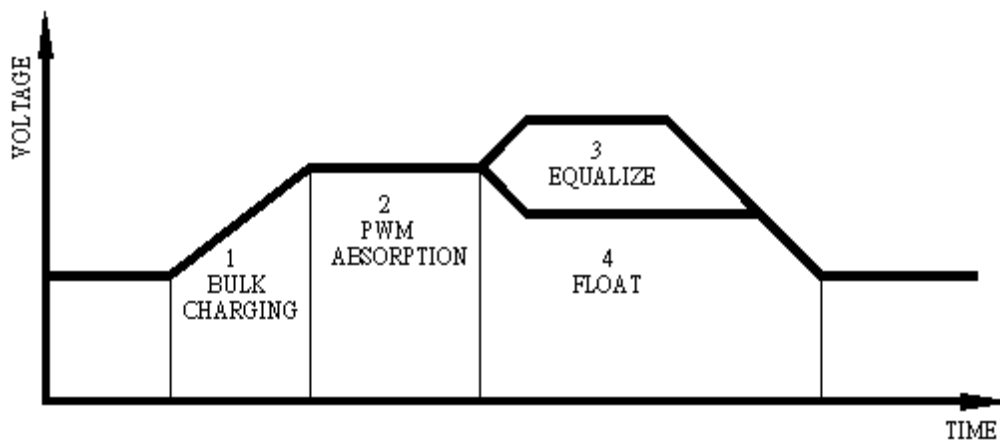

Figure 4.1.1 Charging Stages

- 1. Bulk Charging:** In this stage, the battery will accept all the current provided by the wind system.
- 2. PWM Absorption:** When the battery reaches the regulation voltage, the PWM begins to hold the voltage constant. This is to avoid over-heating and over-gassing the battery. The current will taper down to safe levels as the battery becomes more fully charged.
- 3. Equalization:** Many batteries benefit from a periodic boost charge to stir the electrolyte, level the cell voltages, and complete the chemical reactions.
- 4. Float:** When the battery is fully recharged, the charging voltage is reduced to prevent further heating or gassing of the battery.

4.2 Standard Battery Charging Programs

The WindStar provides 8 standard battery charging algorithms (programs) that are selected with the DIP switches. These standard algorithms are suitable for lead-acid batteries ranging from sealed (gel, AGM, maintenance free) to flooded to L-16 cells and Ni-cad etc.

The table below summarizes the major parameters of the standard charging algorithms. Note that all the voltages are for 12V systems (24V = 2X, 48V = 4X).

All values are 25°C (77°F).

DIP Switches (4-5-6)	A Battery Type	B Bulk Voltage	C Float Voltage	D Equalize Voltage	E Equalize Time (hours)	F Equalize Interval (days)
off-off-off	1 – Sealed	14.0	13.4	None	-	-
off-off-on	2 – Sealed	14.1	13.4	14.2	1	28
off-on-off	3 - Sealed	14.3	13.4	14.4	2	28
off-on-on	4 - Flooded	14.4	13.4	15.1	3	28
on-off-off	5 - Flooded	14.6	13.4	15.3	3	28
on-off-on	6 - Flooded	14.8	13.4	15.3	3	28
on-on-off	7 - L-16	15.0	13.4	15.3	3	14
on-on-on	8-NiCad	16.0	14.5	None	-	-

Table 4.2 Standard Battery Charging Programs

A. Battery Type– These are generic lead-acid and Ni-cad battery types. *See Section 8.0 for more information about battery types and appropriate battery charging.*

B. BULK Voltage–This is the PWM Absorption stage with constant voltage charging. The “PWM voltage” is the maximum battery voltage that will be held constant. As the battery becomes more charged, the charging current tapers down until the battery is fully charged.

C. Float Voltage–When the battery is fully charged, the charging voltage will be reduced to 13.4 volts for all battery types.

D. Equalization Voltage–During an equalization cycle, the charging voltage will be held constant at this voltage.

E. Equalization Time–The charging at the selected equalization voltage will continue for this number of hours. This may take more than one day to complete.

F. Equalization Interval–Equalizations are typically done once a month. Most of the cycles are 28 days so the equalization will begin on the same day of the month. It can be set by Dip Switch 4~6 for different interval days. Each new cycle will be reset as the equalization starts so that a setting day period will be maintained.

These 8 standard battery charging algorithms will perform well for the majority of battery systems.

Chapter 5 Diversion Charge Control

As the battery becomes fully charged, the WindStar will divert excess current from the battery to a dedicated diversion load. This diversion load must be large enough to absorb all the excess energy, but not too large to cause a controller overload condition.

5.1 Diversion Charge Control

The WindStar will use PWM charging regulation to divert excess current to an external load. As the battery becomes fully charged, the FET switches are closed for longer periods of time to direct more current to the diversion load.

As the battery charges, the diversion duty cycle will increase. When fully charged, all the source energy will flow into the diversion load if there are no other loads. The generating source is typically a wind or hydro generator.

The most important factor for successful diversion charge control is the correct sizing of the diversion load.

If you are not confident and certain about the installation, a professional installation by your dealer is recommended.

5.2 Diversion Current Ratings

The maximum diversion load current capability for the WindStar WS-120C is 120 amps. The diversion loads must be sized so that the peak load current cannot exceed the maximum rating.

5.3 Standard Diversion Battery Charging Programs

The SunStar provides 8 standard diversion charging algorithms (programs) that are selected with the DIP Switches.

The table below summarizes the major parameters of the standard diversion battery charging algorithms. Note that all the voltages are for 12V systems (24V = 2X, 48V = 4X).

All values are 25°C (77°F).

DIP Switches (4-5-6)	A Bulk Voltage	B Float Voltage	C Equalize Voltage	D Equalize Time (hours)	E Equalize Interval (days)
off-off-off	14.0	13.4	None	-	-
off-off-on	14.1	13.4	14.2	1	28
off-on-off	14.3	13.4	14.4	2	28
off-on-on	14.4	13.4	15.1	3	28
on-off-off	14.6	13.4	15.3	3	28
on-off-on	14.8	13.4	15.3	3	28
on-on-off	15.0	13.4	15.3	3	14
on-on-on	16.0	14.5	-	-	-

Table 5.3 Standard Diversion Charging Programs

- A. PWM BULK Voltage** - This is the PWM Absorption stage with constant voltage charging. The PWM absorption voltage is the maximum battery voltage that will be held constant.
- B. Float Voltage** - When the battery is fully charged, the charging voltage will be reduced to 13.4 volts for all diversion settings.
- C. Equalization Voltage** - During an equalization cycle, the charging voltage will be held constant at this voltage. Equalizations are manual, and can be selected for automatic.
- D. Equalization Time**- Charging at the selected equalization voltage will continue for this setting number of hours.
- E. Equalization Interval** - Equalizations are typically done once a month cycles can be set in the Equalization Interval in units of days so the equalization will begin according to the setting value. Each new cycle will be reset as the equalization starts.

5.4 Selecting the Diversion Load

It is critical that the diversion load be sized correctly. If the load is too small, it cannot divert enough power from the source (wind, hydro, etc). The battery will continue charging and could be overcharged. If the diversion load is too large, it will draw more current than the rating of the WindStar.

CAUTION: The diversion load must be able to absorb the full power output of the source, but the load must never exceed the current rating of the WindStar wind charger. Otherwise, the battery can be overcharged and damaged.

5.5 Capacity

1. When WS-120C connects with 48VDC batteries, it can support 6KW Wind Turbine.
2. When WS-120C connects with 24VDC batteries, it can support 3KW Wind Turbine.
3. When WS-120C connects with 12VDC batteries, it can support 1.5KW Wind Turbine.

Chapter 6 Trouble Shooting

General Troubleshooting

WindStar is not powering up

- Confirm that all circuit breakers and switches in the system are closed
- Check all fuses
- Check for loose wiring connections and wiring continuity
- Verify that the battery voltage is not below 9Vdc
- Verify that the battery power connection is not reversed polarity

Troubleshooting Charging

- Over-charging or under-charging the battery
- DIP switch settings may be wrong
- Over-temperature condition is reducing the charging current (heat sink cooling may be blocked)
- Voltage drop between WindStar and battery is too high
- Load is too large and is discharging the battery

Not charging the battery

- DIP switch settings may be wrong (check each switch position carefully)
- Circuit breaker or disconnect is open
- Reversed polarity connections at the PMG terminals (PMG: Permanent Magnet Generator)
- Short circuit in the wind system has eliminated part of the wind power output
- Wind energy is not providing enough current
- Battery is failing and cannot hold a charge

Troubleshooting Diversion Control

- Diversion load is too small so PWM reaches 99%
- Diversion load is burned out so PWM reaches 99%
- Diversion load is too large so WindStar faults on overcurrent
- An overtemperature condition may have caused the load to be disconnected
- Voltage drops between the WindStar and battery are too high

Chapter 7 Battery Information

The standard battery charging programs in the WindStar charger, as described in Section 4.2, are typical charging algorithms for four battery types:

- sealed (VRLA)
- flooded (vented)
- L-16 group
- Nicad and NiFe

CAUTION: Never attempt to charge a primary (non-rechargeable) battery.

All charging voltages noted below will be for 12V batteries at 25°C.

7.1 Sealed Batteries

The general class of sealed batteries suitable for renewable systems are called VRLA (Valve Regulated Lead-Acid) batteries. The two main characteristics of VRLA batteries are electrolyte immobilization and oxygen recombination. As the battery recharges, gassing is limited and is recombined to minimize the loss of water.

The two types of VRLA batteries most often used in renewable systems are AGM and Gel.

AGM:

Absorbed Glass Mat batteries are still considered to be a “wet cell” because the electrolyte is retained in fiberglass mats between the plates. Some newer AGM battery designs recommend constant voltage charging to 2.45 volts/cell (14.7V). For cycling applications, charging to 14.4V or 14.5V is often recommended.

AGM batteries are better suited to low discharge applications than daily cycling. These batteries should not be equalized since gassing can be vented which causes the battery to dry out. There is also a potential for thermal runaway if the battery gets too hot, and this will destroy the battery. AGM batteries are affected by heat, and can lose 50% of their service life for every 8°C (15°F) over 25°C (77°F).

It is very important not to exceed the gas recombination capabilities of the AGM. The optimum charging temperature range is from 5 to 35°C (40 to 95°F).

Gel:

Gel batteries have characteristics similar to AGM, except a silica additive immobilizes the electrolyte to prevent leakage from the case. And like AGM, it is important to never exceed the manufacturer’s maximum charging voltages. Typically, a gel battery is recharged in cycling applications from 14.1V to 14.4V. The gel design is very sensitive to overcharging.

For both AGM and Gel batteries, the goal is for 100% recombination of gasses so that no water is lost from the battery. True equalizations are never done, but a small boost charge may be needed to balance the individual cell voltages.

Other Sealed Batteries:

Automotive and “maintenance-free” batteries are also sealed. However, these are not discussed here because they have very poor lifetimes in renewable cycling applications.

NOTE: Consult the battery manufacturer for the recommended charging settings for the battery being used.

7.2 Flooded Batteries

Flooded (vented) batteries are preferred for larger cycling renewable systems.

The advantages of flooded batteries include:

- ability to add water to the cells
- deep cycle capability
- vigorous recharging and equalization
- long operating life

In cycling applications, flooded batteries benefit from vigorous charging and equalization cycles with significant gassing. Without this gassing, the heavier electrolyte will sink to the bottom of the cell and lead to stratification. This is especially true with tall cells.

Hydrocaps can be used to limit the gassing water loss.

Note that a 4% mixture of hydrogen in air is explosive if ignited. Make certain the battery area is well ventilated.

Typical equalization voltages for flooded batteries are from 15.3 volts to 16 volts.

However, a renewable system is limited to what the renewable system can provide. If the equalization voltage is too high, the array I-V curve may go over the “knee” and sharply reduce the charging current.

Lead-Calcium:

Calcium batteries charge at lower voltages (14.2 to 14.4 typically) and have strong advantages in constant voltage or float applications. Water loss can be only 1/10th of antimony cells. However, calcium plates are not as suitable for cycling applications.

Lead-Selenium:

These batteries are similar to calcium with low internal losses and very low water consumption throughout their life. Selenium plates also have poor cycling life.

Lead-Antimony:

Antimony cells are rugged and provide long service life with deep discharge capability. However, these batteries self-discharge much faster and the selfdischarging increases up to five times the initial rate as the battery ages. Charging the antimony battery is typically from 14.4V to 15.0V, with a 120% equalization overcharge. While the water loss is low when the battery is new, it will increase by five times over the life of the battery.

There are also combinations of plate chemistries that offer beneficial tradeoffs. For example, low antimony and selenium plates can offer fairly good cycling performance, long life, and reduced watering needs.

NOTE: Consult the battery manufacturer for the recommended charging settings for the battery being used.

7.3 L-16 Cells

One particular type of flooded battery, the L-16 group, is often used in larger renewable systems. The L-16 offers good deep-cycle performance, long life, and low cost.

The L-16 battery has some special charging requirements in a renewable system. A study found that nearly half of the L-16 battery capacity can be lost if the regulation voltage is too low and the time between finish-charges is too long. One standard charging program in the SunStar is specifically for L-16 batteries, and it provides for higher charging voltages and more frequent equalizations. Additional equalizations can also be done manually with the pushbutton.

NOTE: The best charging algorithm for flooded, deep-cycle batteries depends on the normal depth-of-discharge, how often the battery is cycled, and the plate chemistry. Consult the battery manufacturer for the recommended charging settings for the battery being used.

7.4 Nicad and NiFe Batteries

The WindStar is compatible with Nicad (nikel-cadmium), NiFe (nikel-iron) and alkaline type batteries which must be charged to a higher voltage level to achieve a full charge. When Nicad mode is selected, the equalization process is disabled.