

*INVERTEK®*  
*WINDTAR MPPT SERIES*

WIND MPPT CHARGER

WS-120CX / WS-80CX / WS-50CX

Installation and Operation Manual



MANUAL VER.1, 31-Dec-2010



**RICH**  
ELECTRIC

# CONTENTS

<b>Introduction .....</b>	<b>IV</b>
<b>Feature .....</b>	<b>IV</b>
<b>Specification.....</b>	<b>VI</b>
<b>Dimension .....</b>	<b>VIII</b>
<b>Chapter 1 Installation.....</b>	<b>1-1</b>
<b>1.1 Loads Requirement.....</b>	<b>1-1</b>
<b>1.2 Battery Voltage System .....</b>	<b>1-1</b>
<b>1.3 PV Array Voltage.....</b>	<b>1-1</b>
<b>1.4 Maximum Voc .....</b>	<b>1-1</b>
<b>1.5 Shunt (BCS).....</b>	<b>1-2</b>
<b>1.6 Battery Temperature Sensor (BTS-3).....</b>	<b>1-2</b>
<b>1.7 Battery Voltage Sensing (BVS).....</b>	<b>1-2</b>
<b>1.8 Wiring Diagram .....</b>	<b>1-2</b>
<b>1.9 Installation Steps.....</b>	<b>1-5</b>
<b>Chapter 2 Wiring .....</b>	<b>2-1</b>
<b>2.1 Front Panel Display .....</b>	<b>2-1</b>
<b>2.2 Control Terminal Connection.....</b>	<b>2-3</b>
<b>2.3 Parallel Connection.....</b>	<b>2-5</b>
<b>Chapter 3 User Constants .....</b>	<b>3-1</b>
<b>3.1 Structure of User Constants.....</b>	<b>3-1</b>
<b>3.2 Initialization Stage Flow Chart.....</b>	<b>3-2</b>
<b>3.3 Operation Stage Flow Chart .....</b>	<b>3-4</b>
<b>Chapter 4 Constants List.....</b>	<b>4-1</b>
<b>U Group: Operation .....</b>	<b>4-1</b>
<b>A Group: Initialize .....</b>	<b>4-1</b>
<b>B Group: Battery Setup.....</b>	<b>4-1</b>
<b>C Group: MPPT Setup.....</b>	<b>4-2</b>
<b>D Group: Auxiliary Relay 1 .....</b>	<b>4-3</b>
<b>E Group: Auxiliary Relay 2 .....</b>	<b>4-4</b>
<b>F Group: Parallel Setup .....</b>	<b>4-5</b>
<b>O Group: Operator .....</b>	<b>4-5</b>

<b>G Group: Data Log</b> .....	<b>4-5</b>
<b>Chapter 5 Programming Constants</b> .....	<b>5-1</b>
<b>U Group: Operation</b> .....	<b>5-1</b>
<b>A Group: Initialize</b> .....	<b>5-4</b>
<b>B Group: Battery Setup</b> .....	<b>5-5</b>
<b>C Group: MPPT Setup</b> .....	<b>5-8</b>
<b>D Group: Auxiliary Relay 1</b> .....	<b>5-9</b>
<b>E Group: Auxiliary Relay 2</b> .....	<b>5-12</b>
<b>F Group: Parallel Setup</b> .....	<b>5-12</b>
<b>O Group: Operator</b> .....	<b>5-13</b>
<b>G Group: Data Log</b> .....	<b>5-14</b>
 <b>Chapter 6 Trouble Shooting</b> .....	 <b>6-1</b>

## **Introduction**

The WindStar MPPT is a highly reliable wind battery charger and its most critical feature is to maximize the harvest energy from the 3-Phase wind turbine into the battery by using the advanced technology of Maximum Power Point Tracking (MPPT). The battery types that the WindStar MPPT charge include Flooded Lead Acid (FLA), GEL, AGM chemistries and LiFePO<sub>4</sub> in the range of 12Vdc, 24Vdc, 36Vdc and 48Vdc nominal. The high efficiency of charging ability can be accomplished through a 2 or 3 or 4-stage charging depending on the battery type. It is built-in with the protection to ensure the battery without being overcharged or undercharged.

The wide range of the input generator's voltage and output battery voltage are well applied to the wind system to allow system planner to produce the most of the wind energy. The input voltage range of the WS-120CX MPPT, WS-80CX MPPT and WS-50CX MPPT may be wired in the range of 0 ~ 220Vac nominal and the Maximum Automatic Brake Function is 240 Vdc. The output battery voltage is accepted from 12 to 48Vdc nominal. After wiring up and operation, the built-in intelligent data logging system can track the battery of charge (SOC) and the harvest power produced over the days.

WindStar MPPT may not only well be used in wind off-grid systems but also in wind hybrid systems. With respect to these systems, the 2 auxiliary relays can be programmed by constants setting. The function and programming of the relays helps to control the dump loads. Multiple WindStar MPPT with cables (up to 16 units) can be connected in the larger power systems. The Wind MPPT Charger with the rectifier and braking unit for wind system is required to control and stop the control from overload condition caused by over large wind speed.

Please carefully read through this manual and all the installation instruction and wiring before beginning installation of your WindStar MPPT. The protection and installation equipment should be complied with the local codes. The rated fuses, breakers and external lightning protection should be installed along with WindStar MPPT.

## **Features**

- Integrates Wind Interface (Included the rectifier and braking unit), Maximum Power Point Tracking (MPPT), battery charge management, state of charge information.
- Continuous output Power Rating without de-rating at up to 50°C ambient temperature.
- Built-in Battery Energy Monitor tracks power production and consumption to calculate the energy remaining in battery state of charge (SOC) is displayed in percent full, Amp-hours, Watt-hours, and 90 days of energy-harvest history is stored in the wind MPPT charger.
- Supports Flooded Lead Acid (FLA), GEL, Absorbed Glass Mat (AGM) and LiFePO<sub>4</sub> batteries; 2/3/4-stage charging with adjustable set points for all parameters.

- Up to 220 VAC input voltage from Wind Turbine
- Easy stacking of up to 16 units in parallel for high currents.
- Precision charging of 12V/ 24V/36V/48V batteries with easy set-up and using battery voltage sense (BVS) wires.
- Built-in temperature compensation function for safe and complete charging.
- The Wind MPPT Charger with the rectifier and braking unit for wind system is required to control and stop the control from overload condition caused by over large wind speed.
- The Maximum Automatic Brake Function of the WS-120CX, WS-80CX and WS-50CX Wind MPPT Chargers is 240 VDC. Supply 5 levels of the Automatic Brake Function: 200, 210, 220, 230, 240 VDC (Adjustable)
- When WS-120CX Wind MPPT Charger connects with 48VDC batteries, it can support 7.2KW Wind Turbine.
- Optional Diversion Load

## Specification

MODEL	WS-120CX MPPT	WS-80CX MPPT	WS-50CX MPPT
<b>ELECTRICAL</b>			
Input Voltage Range (no damage)	0 ~ 220 VAC		
Operating Input Voltage Range from PMG (Permanent Magnet Generator)	20 ~ 220 VAC		
	0 ~ 600 Hz		
	Optimal Range: 20 ~ 180 VAC		
System voltage ratings	12, 24, 36, 48 VDC		
Current ratings-Battery Charge Control	120A	80A	50A
Max. Current in the Brake Resistor	120A Diversion load	80A Diversion load	50A Diversion load
DC Output Voltage Range	16 ~ 240 VDC Operating		
	240 VDC Maximum		
Automatic Brake Function	5 Level: 200, 210, 220, 230, 240 VDC (Adjustable) ※ Can be customized for the wind turbines		
<b>Maximum Wind Turbine Capacity</b>			
Charging 48 VDC Batteries	7.2KW	4.8KW	3.0KW
Charging 36 VDC Batteries	5.4KW	3.6KW	2.25KW
Charging 24 VDC Batteries	3.6KW	2.4KW	1.5KW
Charging 12 VDC Batteries	1.8KW	1.2KW	750W
Charge Regulation Modes	Bulk, Absorption, Float, Auto/ Manual Equalization		
Battery Temperature Compensation	5.0 mV per°C , per 2 volt cell		
DC to DC Conversion Capability	12V Battery: 16~240VDC		
	24V Battery: 32~240VDC		
	36V Battery: 48~240VDC		
	48V Battery: 64~240VDC		
Display Status	Built-in 2-line, 20-character LCD with backlight LCD status screen displays input voltage and current, output voltage and current, charge-mode, Battery SOC		
Data Logging	Logs energy harvested for 90 days, LCD displays WH, KWH, AH		
Energy Monitor	LCD shows SOC, AH, WH, and present charge or		

	discharge current. A 50mV/ 500Amp shunt is required to use		
Auxiliary Relays	Two independent relays with from A (SPST) contacts for control of external devices. Contact rating is 3 Amps, 50VDC		
Operation Temperature	Full Power Output to +50°C ambient		
Standby Power	< 2 Watts		
Relative Humidity	0 ~ 100% condensing		
<b>MECHANICAL</b>			
Dimensions (mm)	401 (H) x 258 (W) x 183 (L)		
Weight	8.5 kg	8.15 kg	
Optional Diversion Load			
Specifications subject to change without notice			

## Dimension

Unit: mm

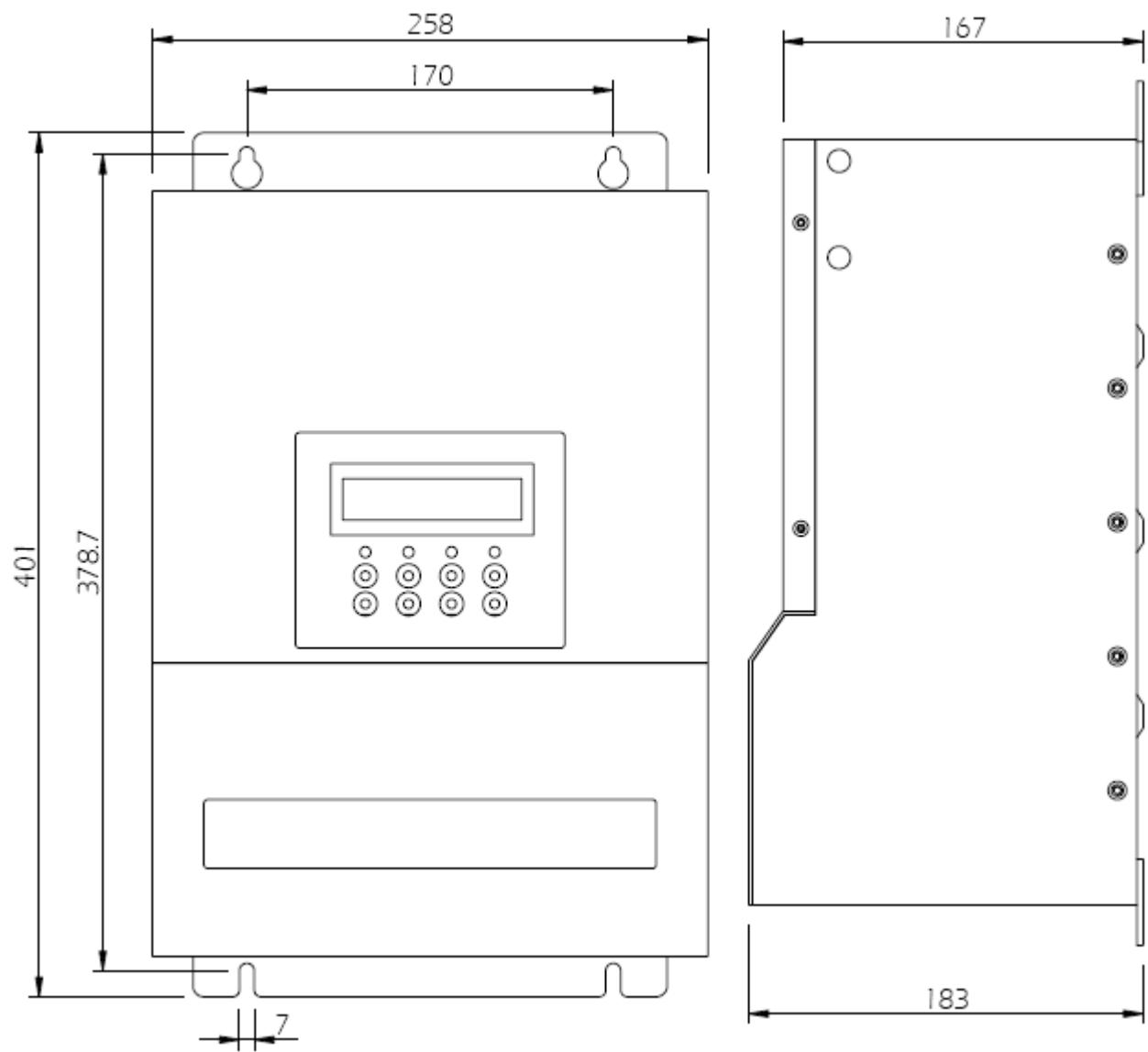
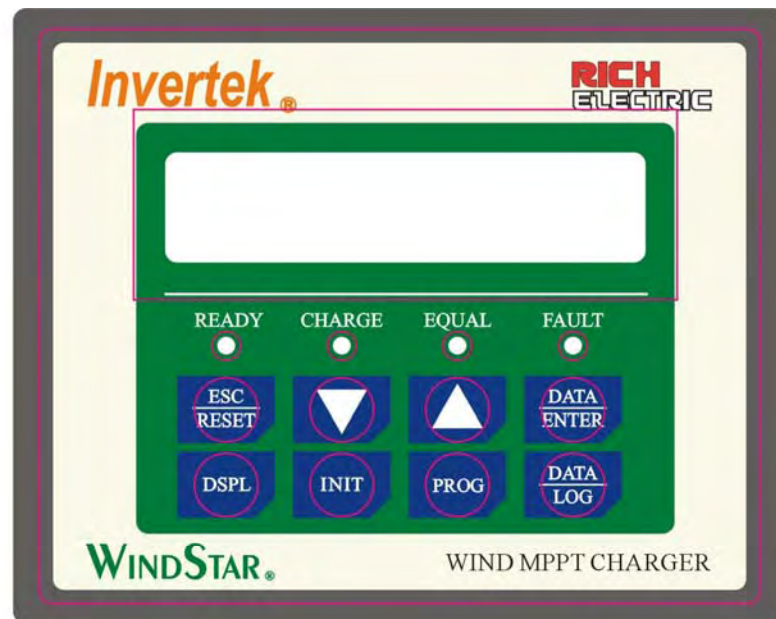

Fig-1

## Label for WS-120CX and WS-80CX Wind MPPT Chargers



	<b>WS-80CX MPPT</b>	-	<b>12-48VDC</b>	-	<b>80AMP</b>	-	<b>16-240VDC</b>
	Model		Battery voltage		Charge current		Input voltage
	<b>WS-120CX MPPT</b>	-	<b>12-48VDC</b>	-	<b>120AMP</b>	-	<b>16-240VDC</b>
	Model		Battery voltage		Charge current		Input voltage

Fig-2

## Label for WS-50CX Wind MPPT Charger

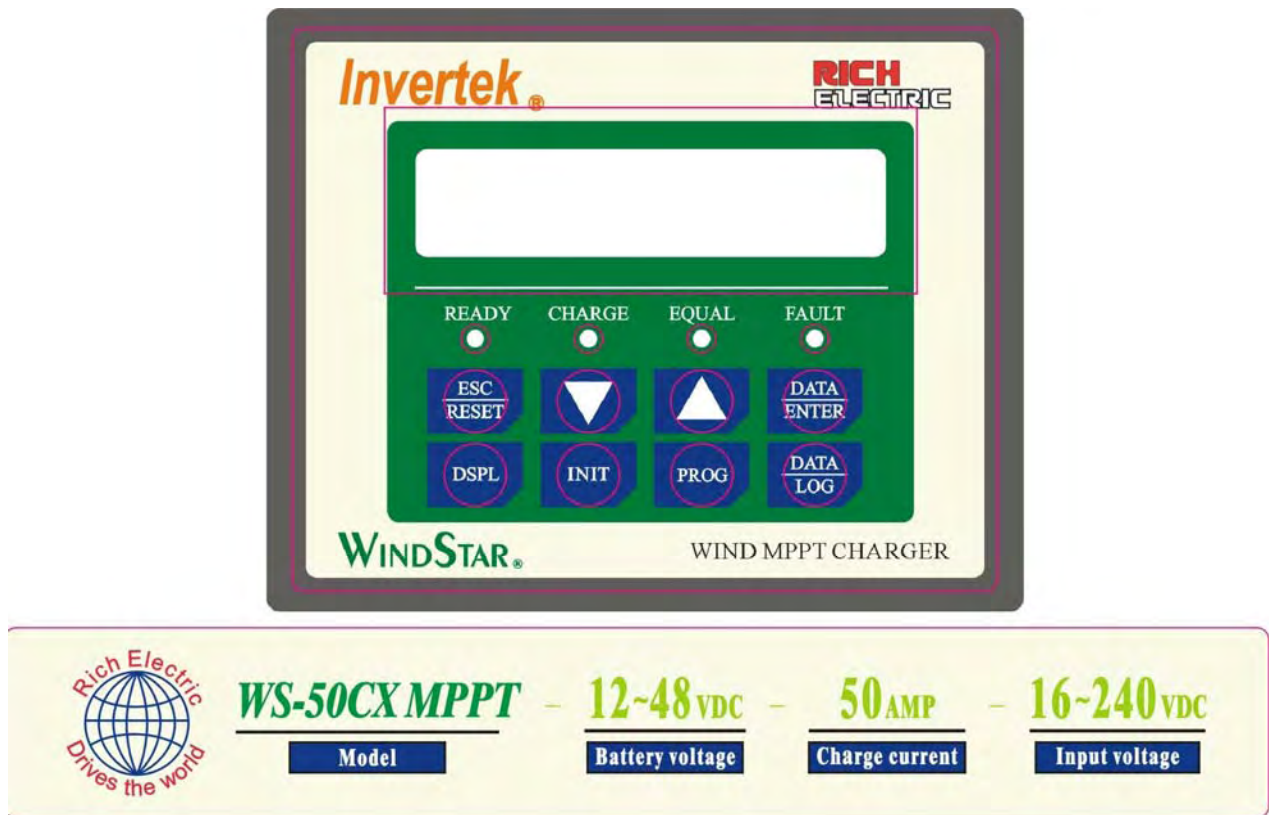

Fig-3

# **Chapter 1 Installation**

## **1.1 Loads Requirement**

The WindStar MPPT series plays a major role in planning your Wind system. The first step in planning an efficient Wind system is to calculate the load requirement. In order to calculate the anticipated load requirement, it is important to determine average and peak load consumption. The possible load growth should also be taken into consideration when planning the load requirement because loads hardly remain static and they grow more frequently than they reduce.

## **1.2 Battery Voltage System**

After the estimate of the power requirement, the required power from the battery will be the next consideration in planning the system. According to the basic rule of the electricity, “Current is the power divided by voltage”, when the power amount increases, it is suggested to raise the battery voltage so the current amount will decrease. The principle is based on the larger amount of current is, the more expensive the circuit protection is. In an example of the 96 watt load, it draws 4 amps at 24V battery system but it draws only 2 amps at 48V system.

## **1.3 Wind Turbine 3-Phase Voltage**

As the WindStar MPPT Series is the Wind Interface and the smart DC to DC converter design, the input voltage range of the WindStar MPPT Series may be wired in the range of 0 ~ 220 Vac nominal (Optimal Range: 20 ~ 180 Vac). This Wind Interface includes the rectifier and braking unit.

## **1.4 Maximum Automatic Brake Voltage**

The maximum automatic brake voltage of the WS-120CX, WS-80CX and WS-50CX Wind MPPT Chargers is 240 Vdc. The protection will be active to shut down the unit when the operating voltage is higher. Wind turbines’ manufacturers have the published data sheet with rated voltage and power as well as the cut-in and maximum wind speed.

WindStar MPPT Series has the adjustable 5-level brake voltages including 200, 210, 220, 230 and 240 Vdc. The adjustable 5-level brake voltages can be customized for the dedicated wind turbine.

## **1.5 Shunt (BCS)**

The Shunt is an optional component and it is required for the WindStar MPPT to achieve to the optimal operation levels and it functions as a hub for connecting measurement sensors. The main purpose of the shunt is to allow the WindStar MPPT to measure current drawing into and out of the battery.

DC load center is where the WindStar MPPT Shunt is recommend to be placed at. Or installing it in an electrical enclosure is also acceptable. Locating the Shunt is essential for safety. Please note that the capacity of the Shunt is 50mV, 500Amp. See page 1-3 for wiring connection terminal.

## **1.6 Battery Temperature Sensor (BTS-3)**

The battery temperature sensor BTS-3 is used to compensate charging by adjusting charging voltage up or down according to the temperature detected by the sensor, see page 1-3 for wiring connection terminal.

The WindStar MPPT requires BTS-3 to be connected for all charging features to be available. WindStar MPPT is able to operate without the sensor but Absorption Trigger set points will be lower and equalization stage will be disabled. BTS-3 can be mounted on the battery posts.

## **1.7 Battery Voltage Sensing (BVS)**

Connecting the red wire to a battery positive bus and the black wire to a battery negative bus within the DC load center, see page 1-3 for wiring connection terminal. Two sense wires may be connected to compensate possible battery cable loss during charging. Be sure to observe correct polarity when installing voltage sense wires or damage will result.

## **1.8 Wiring Diagram**

Before starting to initiate the WindStar MPPT, keep all breakers in the OFF position. When you are ready to start the WindStar MPPT, turn on ONLY the Battery breaker. Do NOT turn on the Wind Turbine breaker until the instruction on LCD shows during WindStar MPPT initialization. The internal electric circuit of the WindStar MPPT can only be powered by the batteries.

The installation environment of WindStar MPPT should be in an area of good ventilation. Never locate the WindStar MPPT in a poorly ventilated battery area because batteries emit the explosive gases. Do not locate the WindStar MPPT within 1 meter of the batteries to ensure the safety condition.

See next page for the wiring diagram of WS-80CX Wind MPPT Charger as an example.

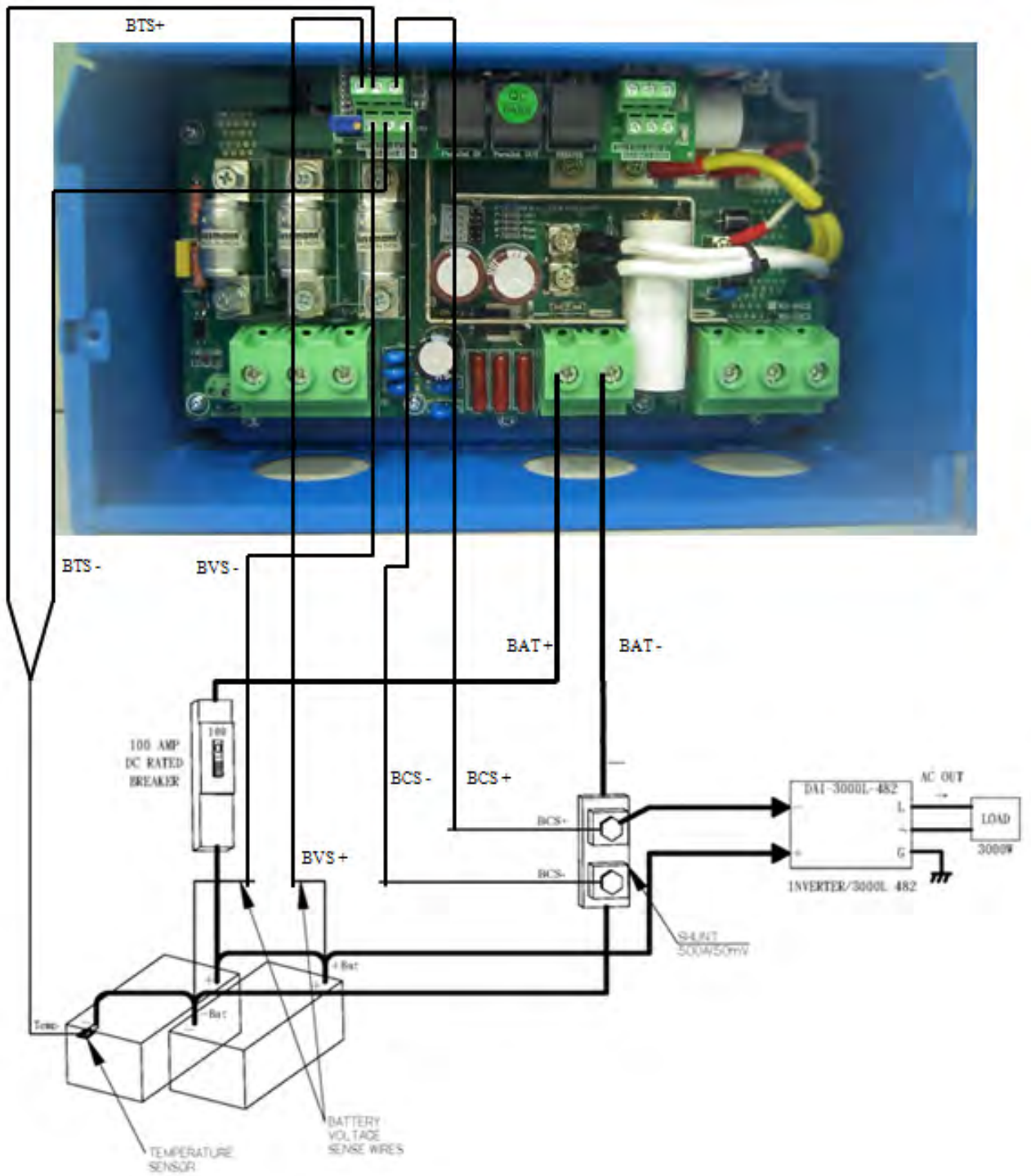

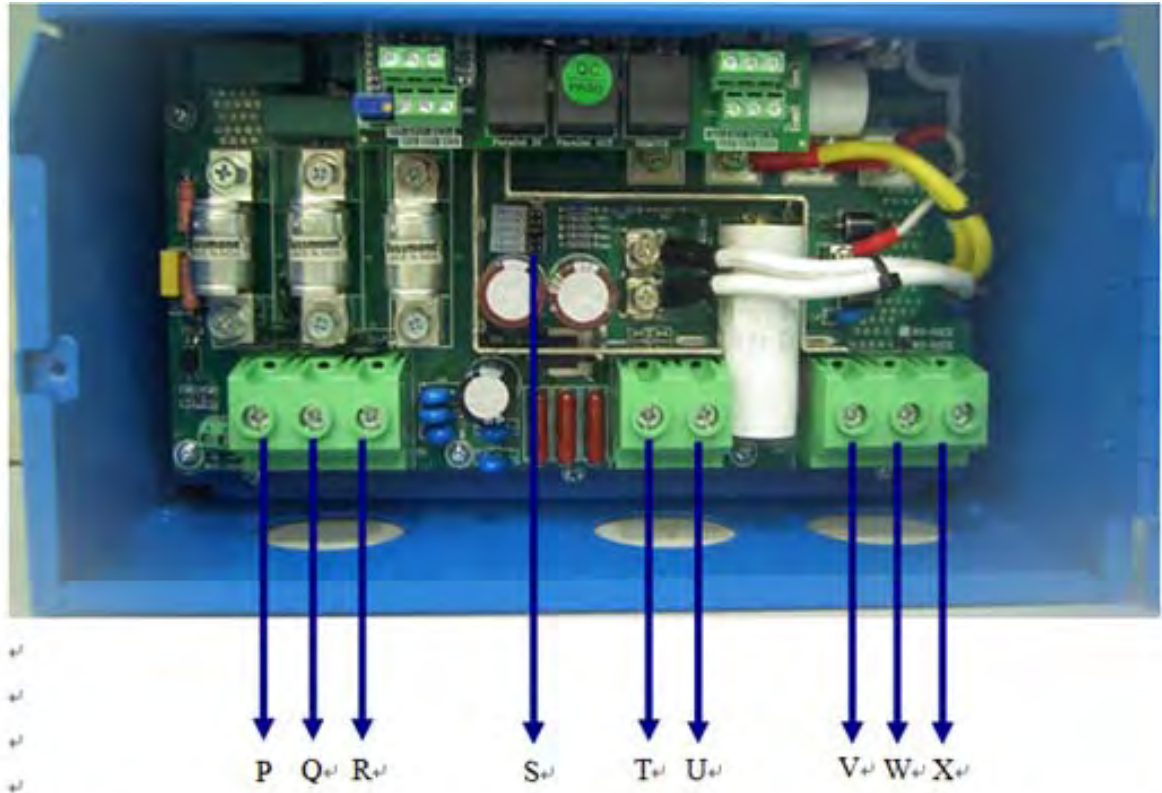

Connections		Details
P	WIND INPUT 1	Connecting terminal for Wind Turbine
Q	WIND INPUT 2	Connecting terminal for Wind Turbine
R	WIND INPUT 3	Connecting terminal for Wind Turbine
S	ABV	Adjustable 5-level Automatic Brake Voltages
T	BAT+	Connecting terminal for battery cable Positive
U	BAT-	Connecting terminal for battery cable Negative
V	DL+	Connecting terminal for Diversion Load Positive
W	DL-	Connecting terminal for Diversion Load Negative
X	PE	Connecting terminal for Ground

Fig-4

## 1.9 Installation Steps

Example: WS-80CX Wind MPPT Charger

Before starting the WS-80CX MPPT, keep the breakers, controllers in OFF position.

1. Locate the battery and WindStar MPPT Series and make sure the safety distance is at least 1 meter long.
2. Install a 100 Amp rated DC breaker and connect it to the Battery + .
3. Install a Shunt of rated 500A/50mV and connect it to the Battery –.
4. Connect the BAT+ terminal of the WindStar MPPT to the DC breaker.
5. Connect the BAT- terminal (next to BAT+) of the WindStar MPPT to the Shunt.
6. Install the AC breaker and connect it to the WIND TURBINE and also to the WIND INPUT terminal of the WS-80CX MPPT.
7. Connect the WIND TURBINE – directly to the PE terminal (next to DL-) of the WS-80CX MPPT.
8. Connect the PE terminal of the WS-80CX MPPT to the system ground.
9. Connect the DL+ terminal of the WS-80CX MPPT to the Diversion Load Positive and connect the DL- terminal of the WS-80CX MPPT to the Diversion Load Negative.
10. To measure the current drawing into and out of the battery, connect the BCS+ terminal of WS-80CX MPPT to the Shunt + and connect the BCS- terminal of WS-80CX MPPT to the Shunt –.
11. To compensate the battery charging due to the temperature difference, connect the BTS+ terminal of WS-80CX MPPT to BTS-3 Battery Temperature Sensor +and connect the BTS- terminal of WS-80CX MPPT to BTS-3 Battery Temperature Sensor –.
- ※ BTS-3 should be located in the battery posts –.
12. To compensate the possible battery cable loss, connect the BVS+ terminal of the WS-80CX MPPT to Battery +, connect the BVS- terminal of the WS-80CX MPPT to Battery – .
13. Finally, connect the DC load+ to the Battery+ and DC load – to Battery – through the Shunt.

## 1.10 Applications

Example: Off-grid systems

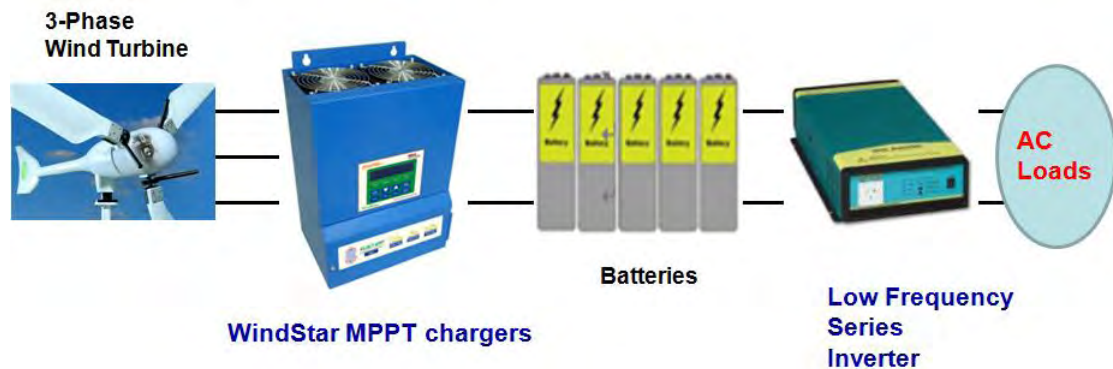

Example: Hybrid system

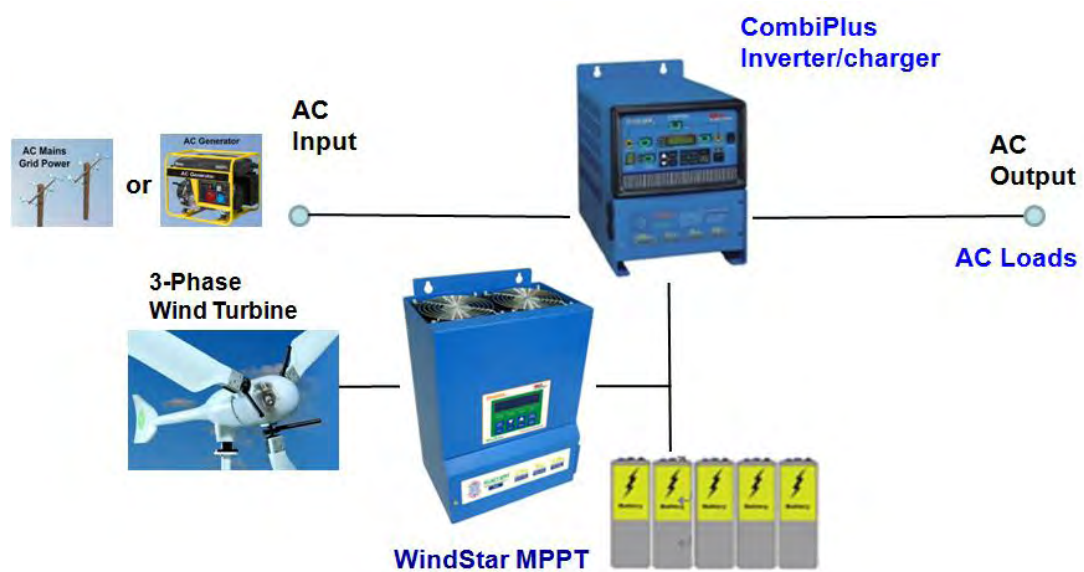





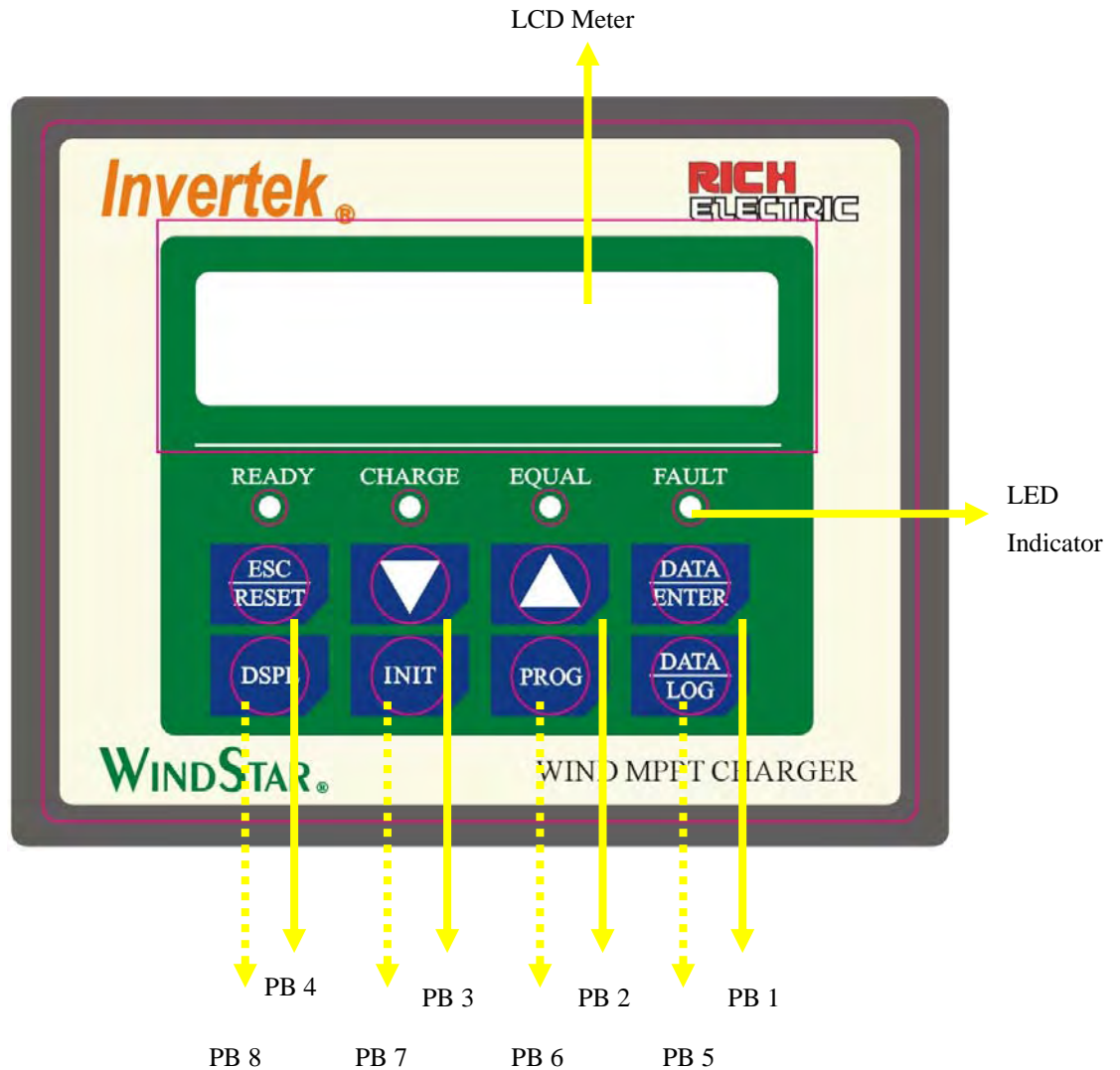



## Chapter 2 Wiring

### 2.1 Front Panel Display



#### 8 Push Buttons

Push buttons	Name	Description
PB1		Data write-in key
PB2		UP key to increment setting values. UP key to go to the next selection or constant.
PB3		DOWN key to decrement setting values. DOWN key to go to the last selection or constant.

<b>PB4</b>		Reset key to reset the fault. ESC key to return to the last selection level.
<b>PB5</b>		Quick function key to the Main Menu: Data Log
<b>PB6</b>		Quick function key to the Main Menu: Programming
<b>PB7</b>		Quick function key to the Main Menu: Initialize
<b>PB8</b>		Quick function key to the Main Menu: Operation

#### 4 LED Indicators

<b>LEDs</b>	<b>Flashing/ Solid</b>	<b>Description</b>				
<b>FAULT</b>	Solid Red	Read the LCD meter for fault condition displayed. 4 fault conditions could be displayed as follows: <table border="1" data-bbox="628 1032 1423 1317" style="margin-left: auto; margin-right: auto;"> <tr> <td style="text-align: center;">ERROR!!! High Input Voltage</td> <td style="text-align: center;">ERROR!!! WindStar Over-Temp.</td> </tr> <tr> <td style="text-align: center;">ERROR!!! Parallel COM Failed</td> <td style="text-align: center;">ERROR!!! Battery Over-Temp.</td> </tr> </table>	ERROR!!! High Input Voltage	ERROR!!! WindStar Over-Temp.	ERROR!!! Parallel COM Failed	ERROR!!! Battery Over-Temp.
ERROR!!! High Input Voltage	ERROR!!! WindStar Over-Temp.					
ERROR!!! Parallel COM Failed	ERROR!!! Battery Over-Temp.					
<b>EQUAL</b>	Flashing Orange	WindStar MPPT unit is in equalization mode. Refer to constant B-09~B-12 for the setting details.				
<b>CHARGE</b>	Flashing Green	WindStar MPPT unit is in charge mode. This indicates that it is functioning properly.				
<b>READY</b>	Solid Green	When the voltage from the Wind Turbine is first received, the WindStar MPPT is in standby mode to charge.				

#### LCD Meter

1 LCD Meter of 20 x 2 characters is built in each WindStar MPPT unit.

## 2.2 Control Terminal Connection

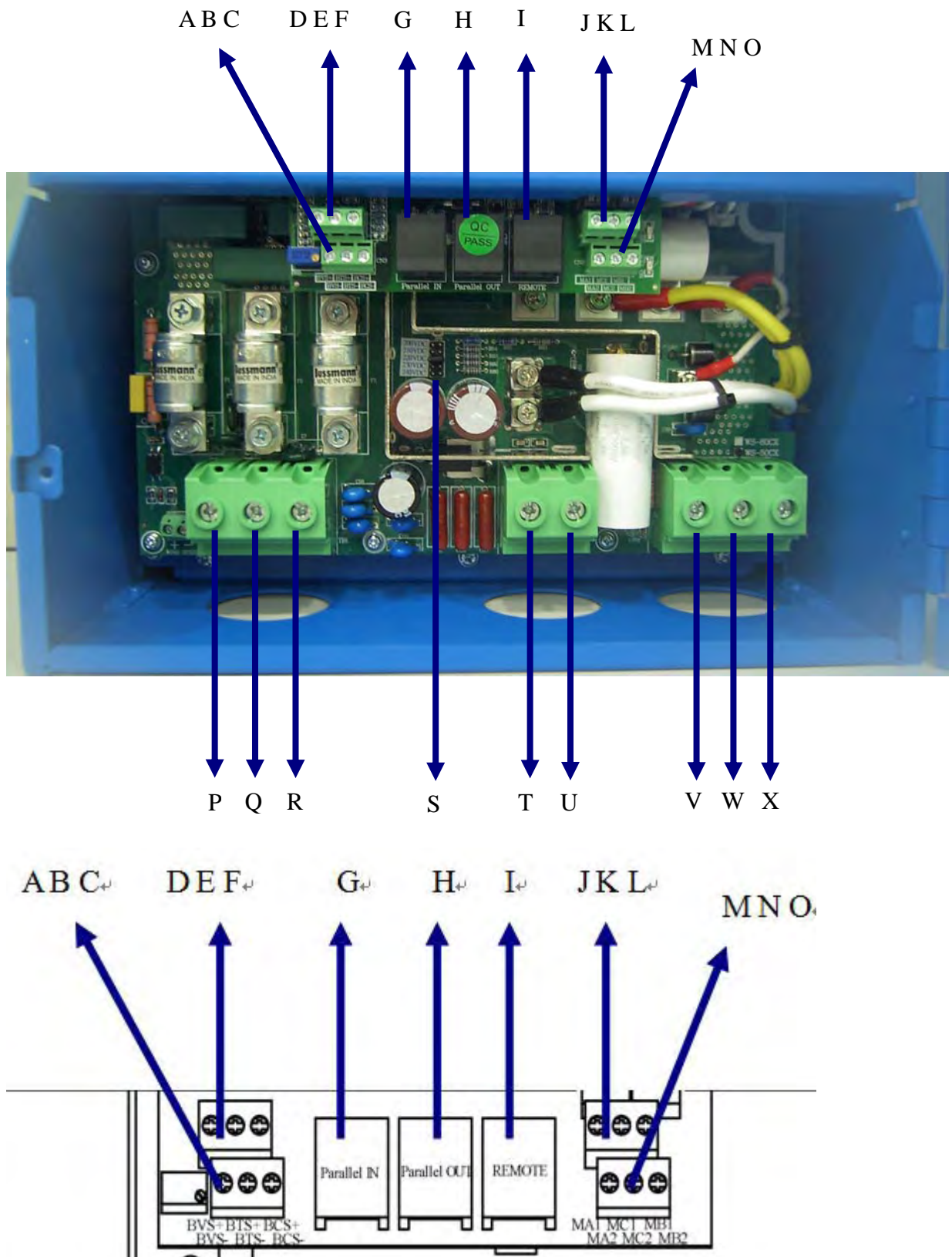

Fig-5

<b>Connections</b>		<b>Details</b>
A	BVS-	Connecting terminal to Battery Voltage feedback Negative
B	BTS-	Connecting terminal for Battery Temperature Sensor Negative
C	BCS-	Connecting terminal for optional Shunt Negative
D	BVS+	Connecting terminal to Battery Voltage feedback Positive
E	BTS+	Connecting terminal for Battery Temperature Sensor Positive
F	BCS+	Connecting terminal for optional Shunt Positive
G	Parallel IN	Connections for parallel input from last WindStar MPPT
H	Parallel OUT	Connections for parallel output
I	Remote	Connecting terminal to Remote Panel Display
J	MA1	Connecting terminal for the contact A of auxiliary 1
K	MC1	Connecting terminal for the common contact of auxiliary 1
L	MB1	Connecting terminal for the contact B of auxiliary 1
M	MA2	Connecting terminal for the contact A of auxiliary 2
N	MC2	Connecting terminal for the common contact of auxiliary 2
O	MB2	Connecting terminal for the contact B of auxiliary 2
P	WIND INPUT 1	Connecting terminal for Wind Turbine
Q	WIND INPUT 2	Connecting terminal for Wind Turbine
R	WIND INPUT 3	Connecting terminal for Wind Turbine
S	ABV	Adjustable 5-level Automatic Brake Voltages
T	BAT+	Connecting terminal for battery cable Positive
U	BAT-	Connecting terminal for battery cable Negative
V	DL+	Connecting terminal for Diversion Load Positive
W	DL-	Connecting terminal for Diversion Load Negative
X	PE	Connecting terminal for Ground

## 2.3 Parallel Connection

The parallel connection of WindStar MPPT series can be up to 16 units (1 Master and 15 Slaves) and in the parallel system, there is only one Shunt which needs to be connected to the Master unit to measure the total accumulated current.

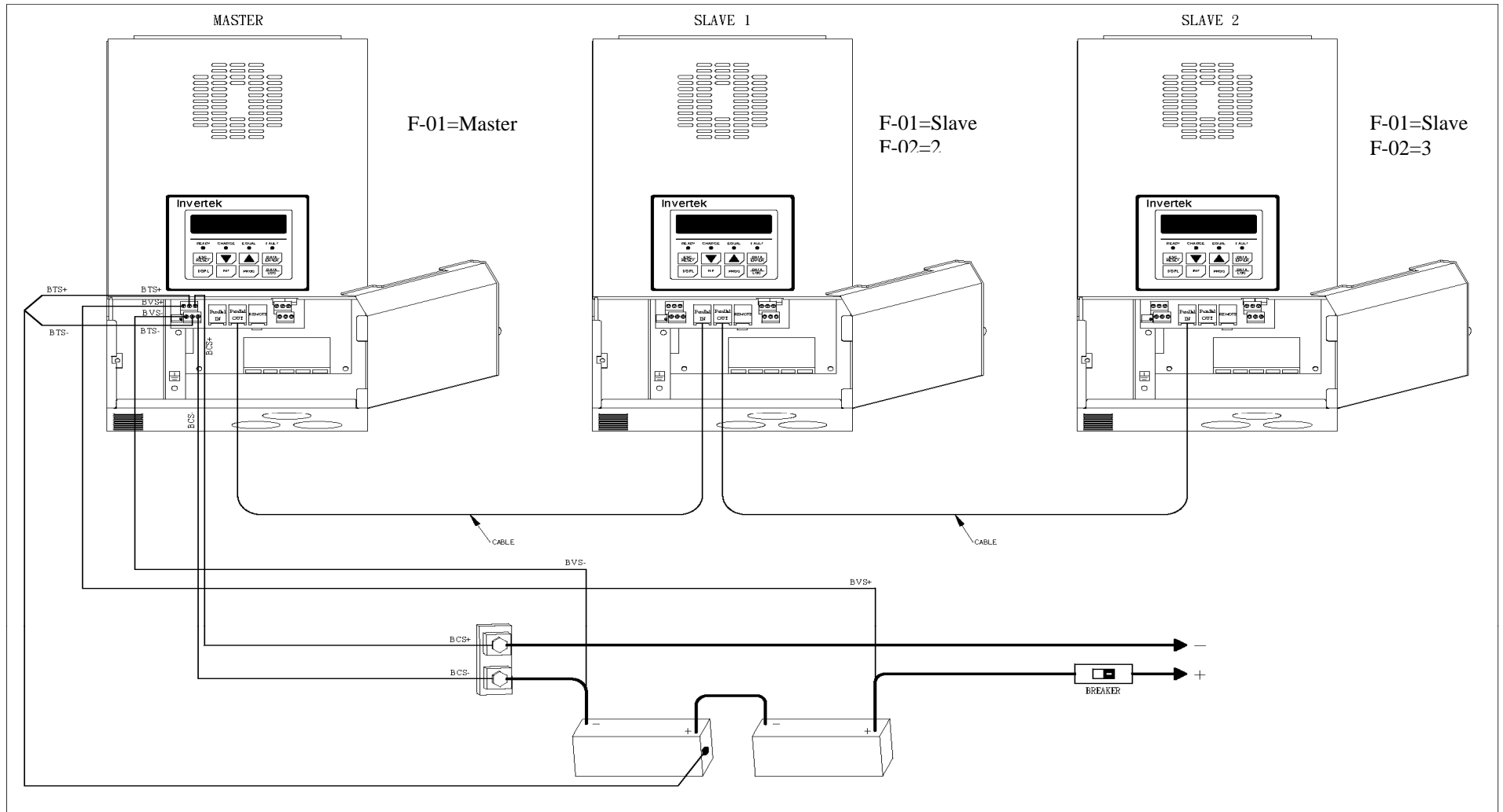
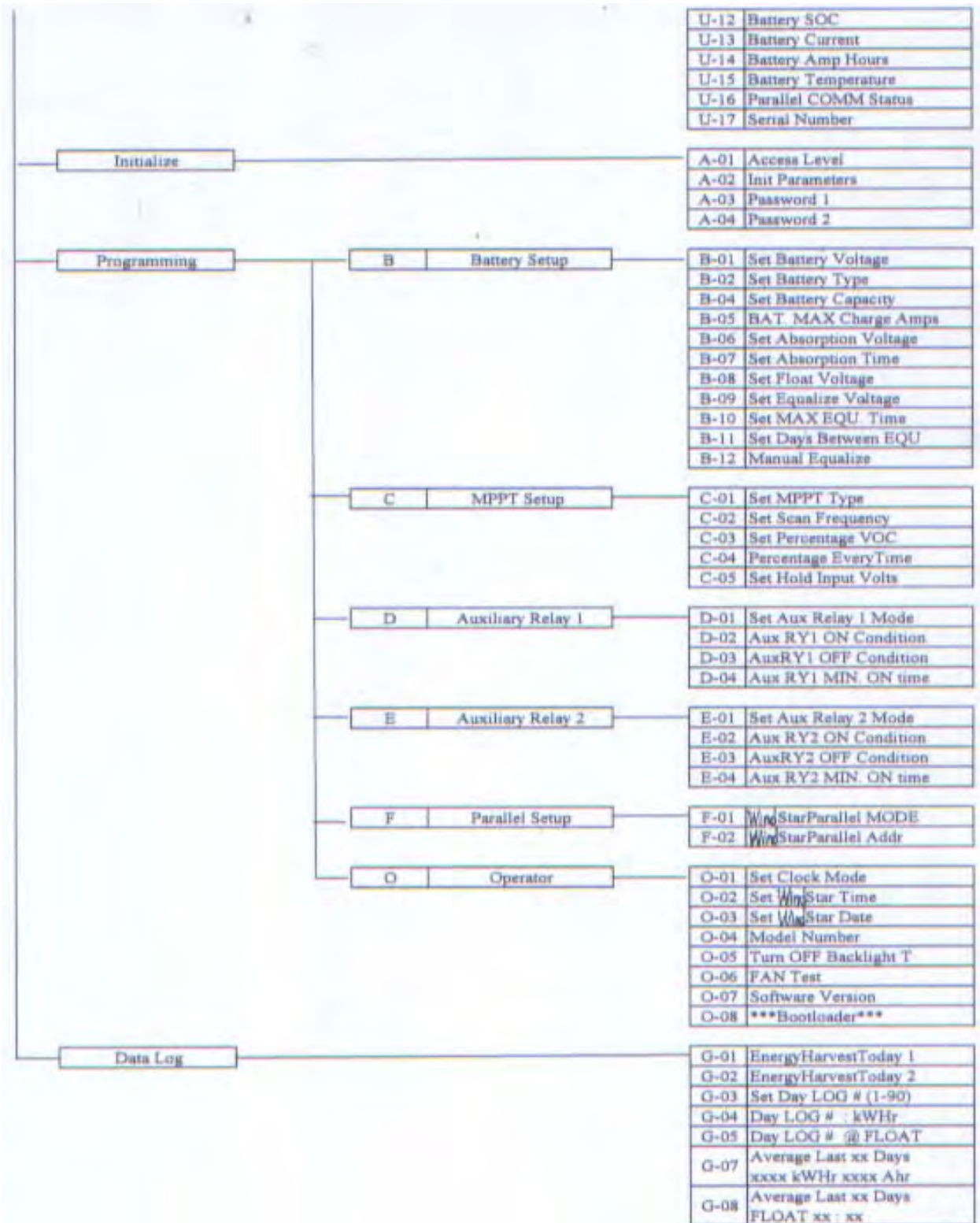

Fig-6

# Chapter 3 User Constants

3.1 The following is the structure of user constants.



3.2 The following is the “Initialization Stage Flow Chart”.

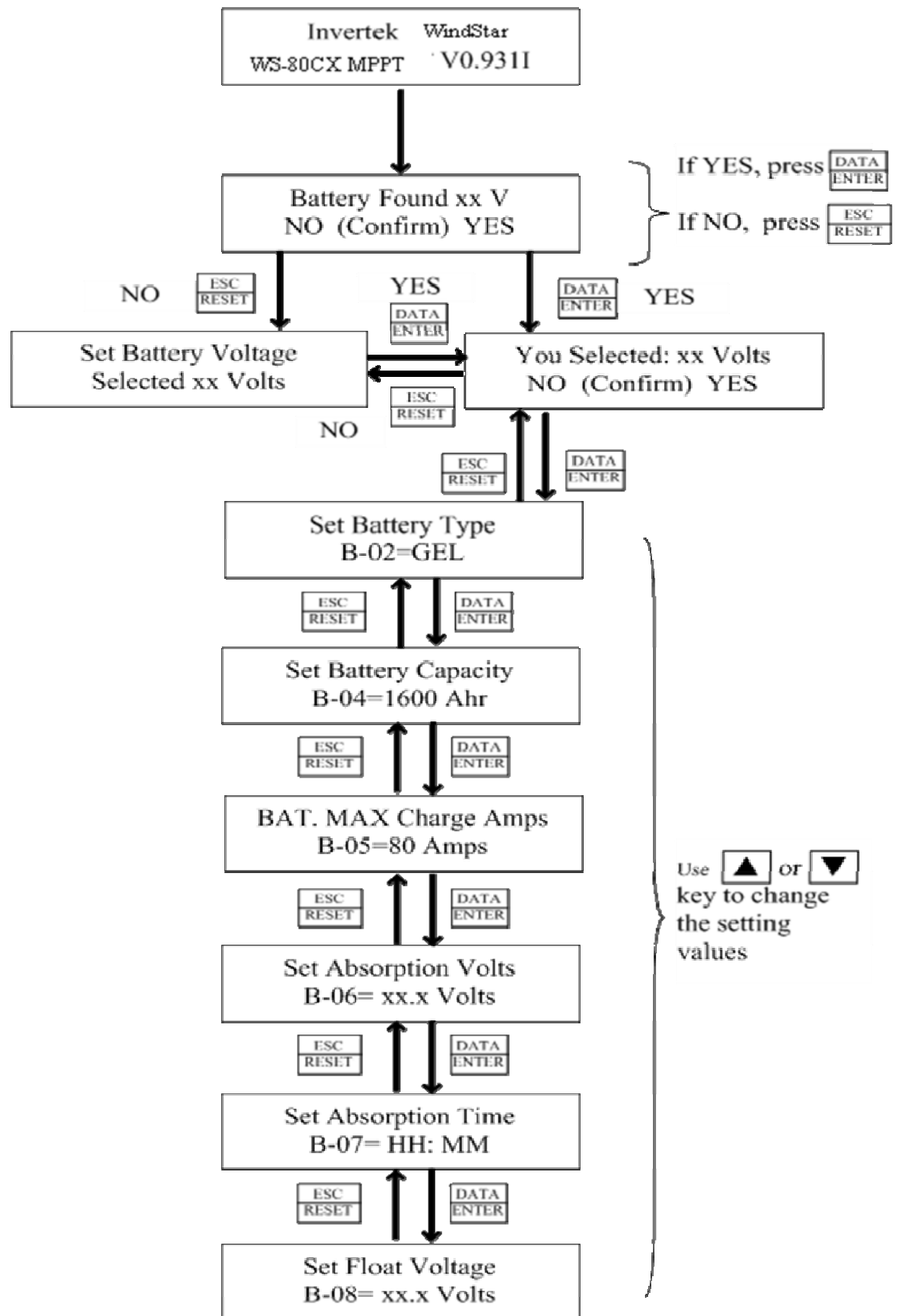

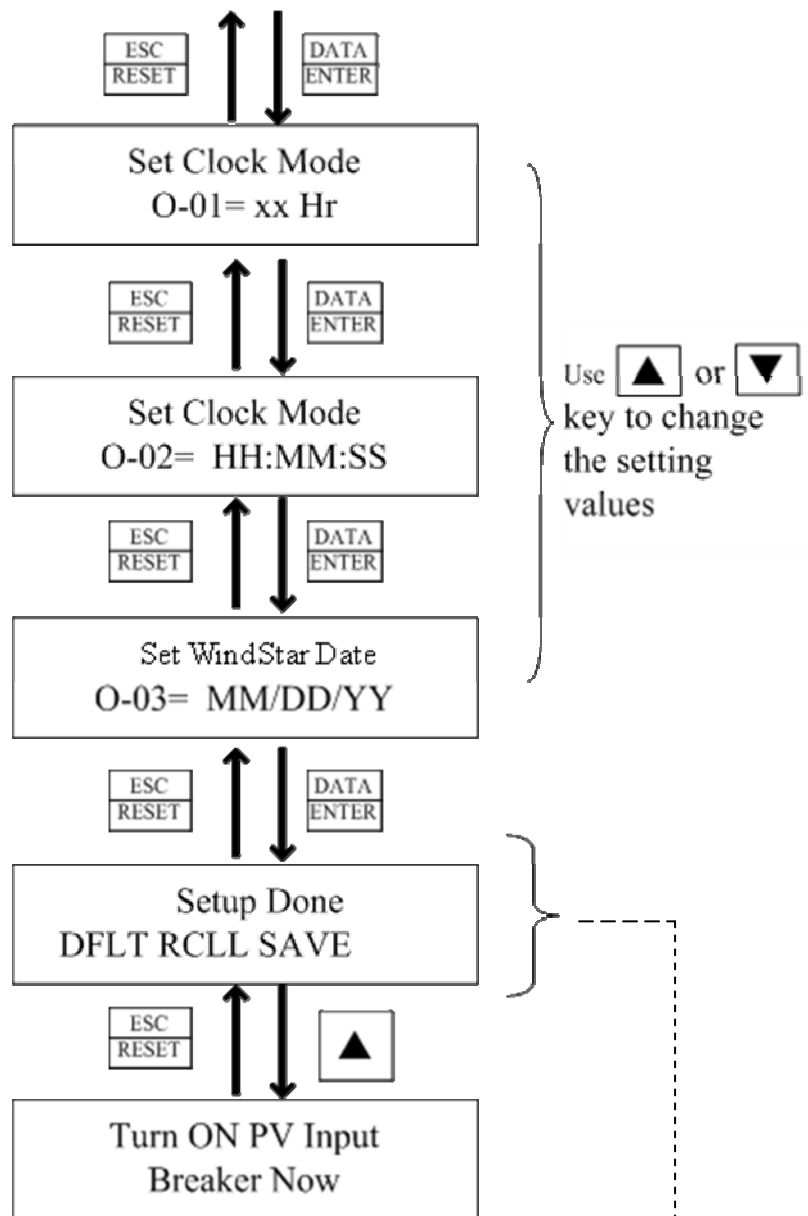

SAVE: If SAVE is selected by pressing ▲ key, the controller will save the entered settings and operate with them

RCLL (RECALL): Pressing ▼ key will return to the last setting prior to entering setup.

DFLT (DEFAULT): If DFLT is selected by pressing ESC  
RESET key, the controller will revert to and operate at default settings based on the original voltage, battery type and capacity entered in the initialization process.

### 3.3 The following is the “Operation Stage Flow Chart”.

#### Main Menu

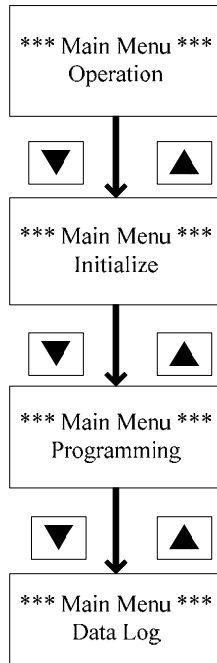

#### Main Menu-Operation

Menu

Constants

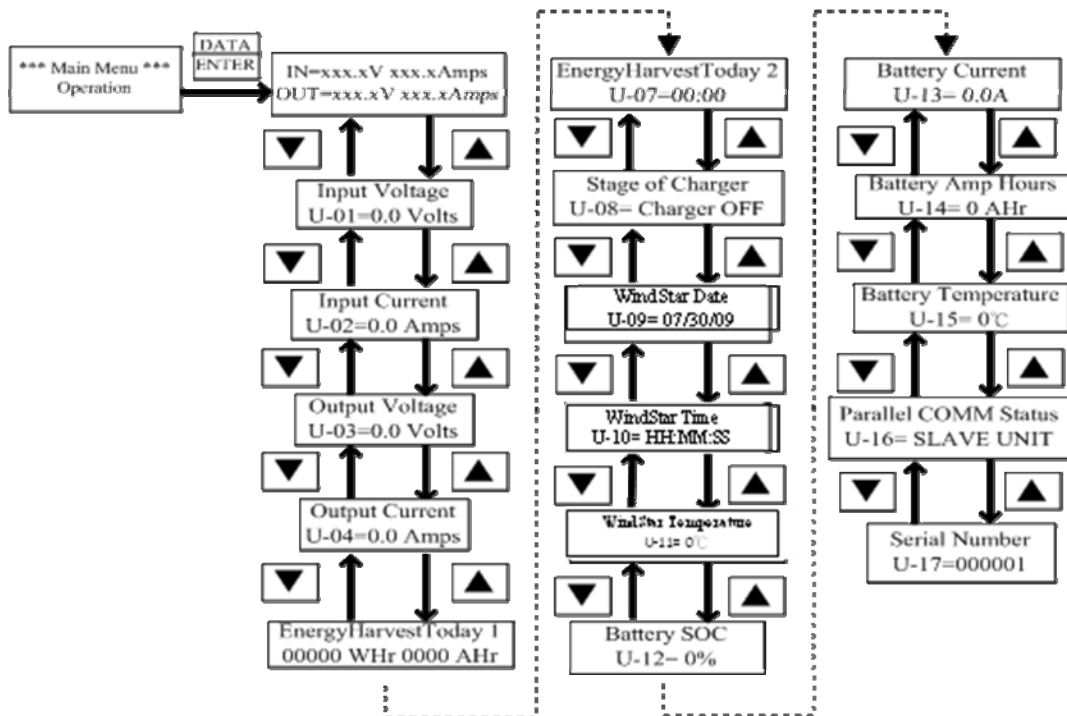

## Main Menu-Initialize

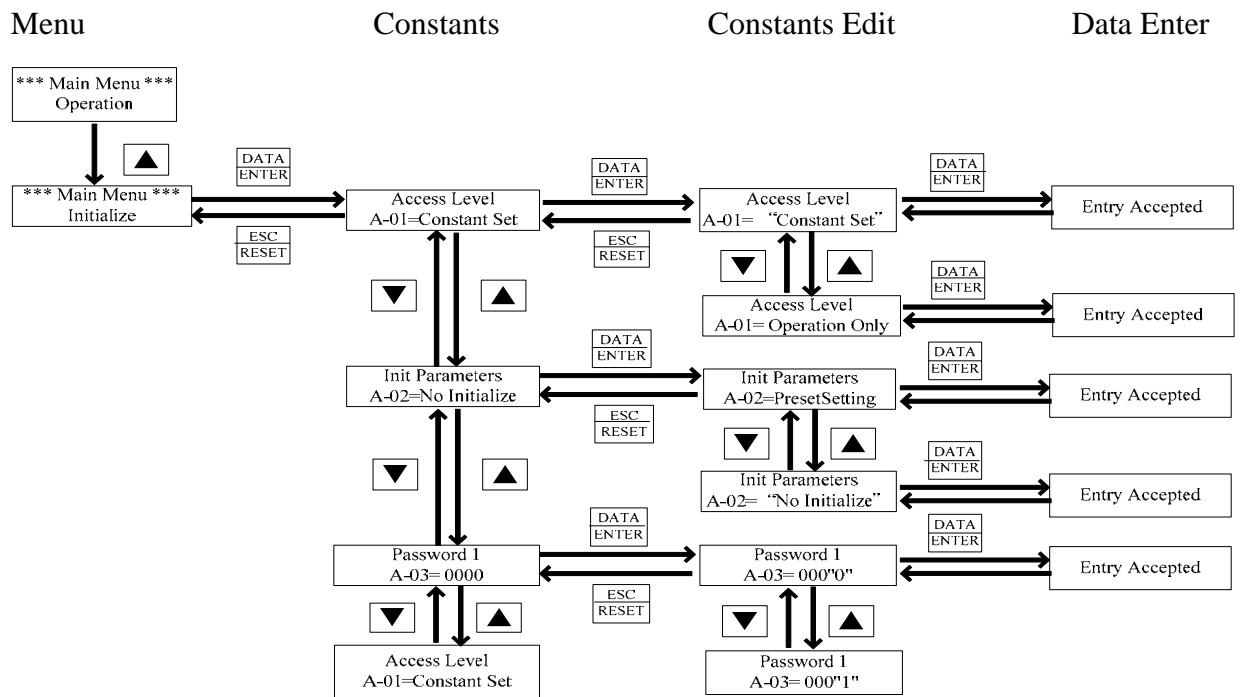

## Main Menu-Programming Group B

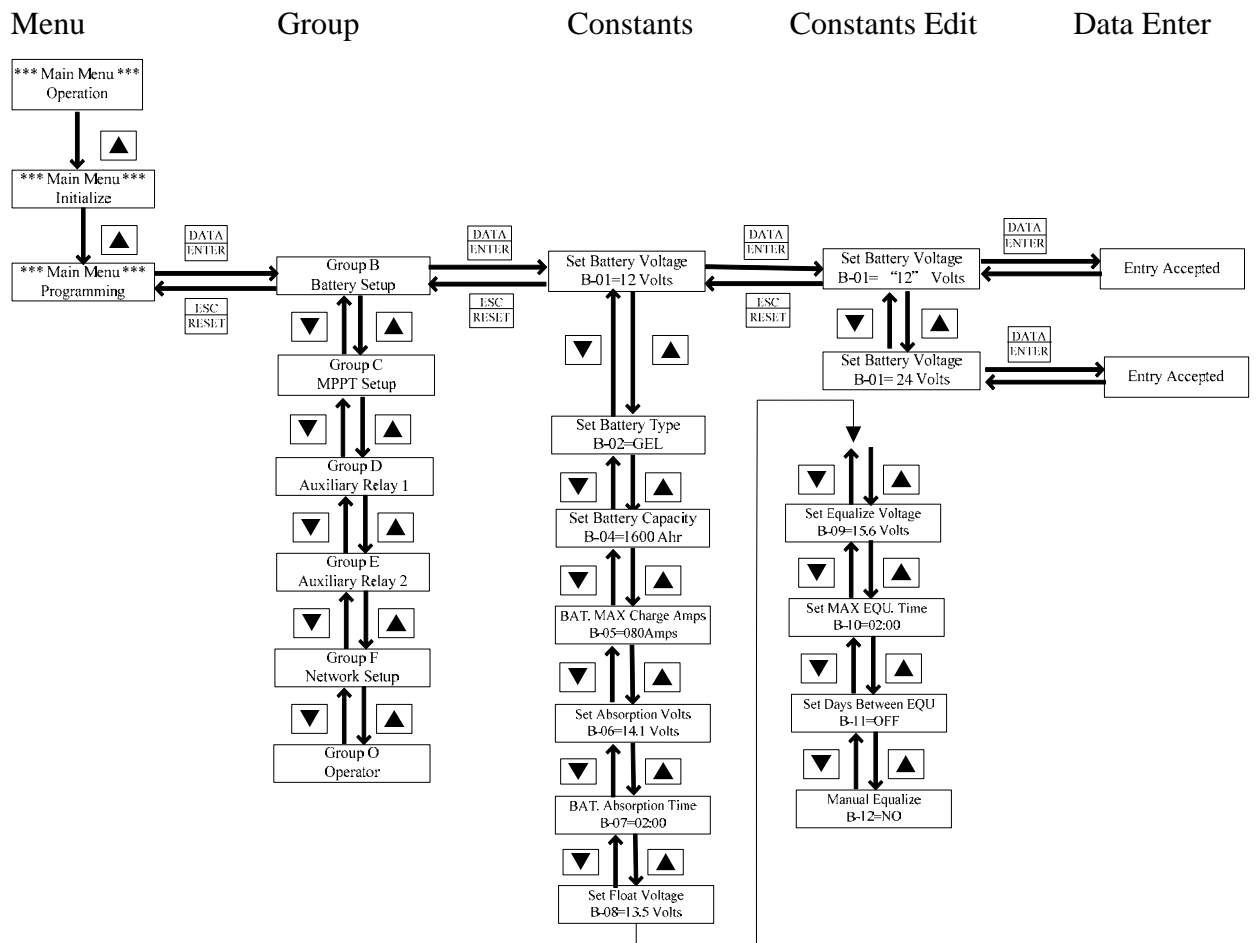

## Main Menu-Programming Group C

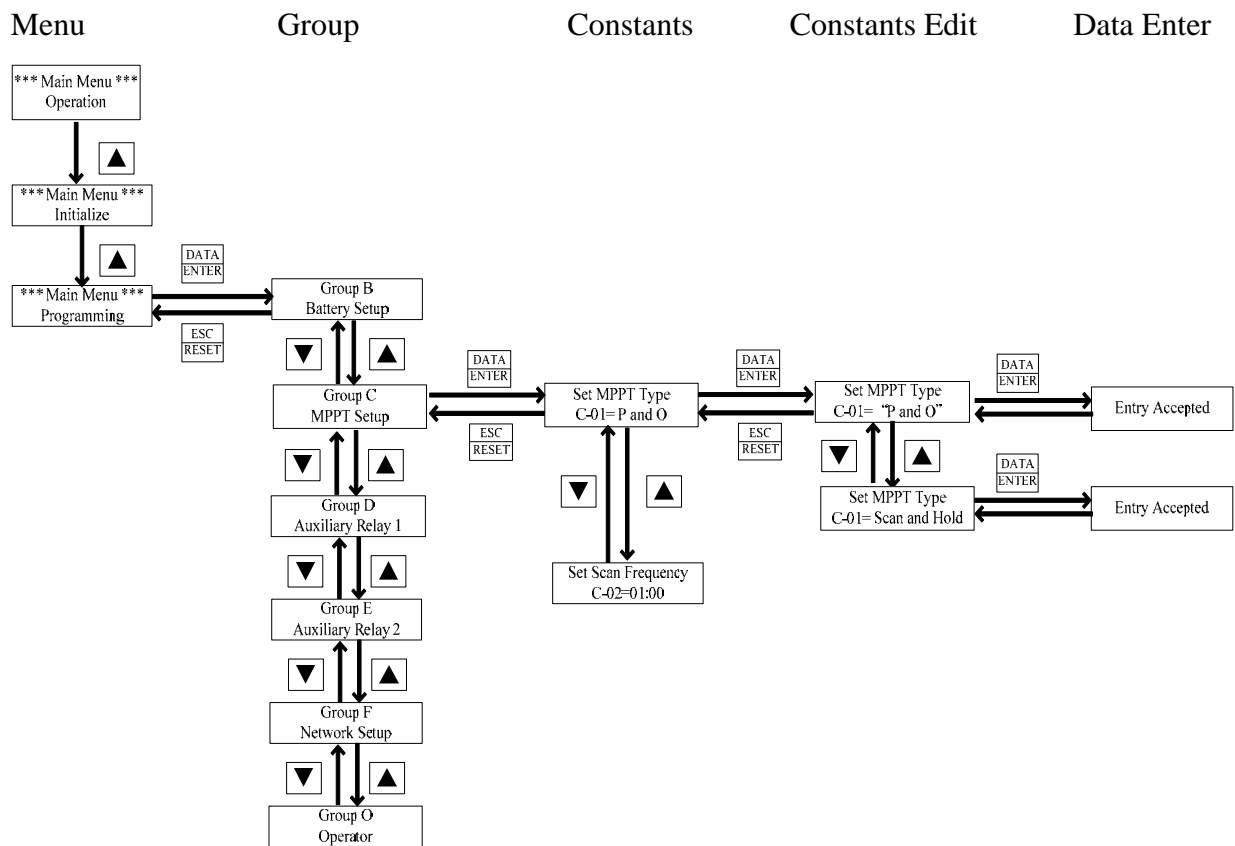

## Main Menu-Programming Group D, D-01= ON or OFF

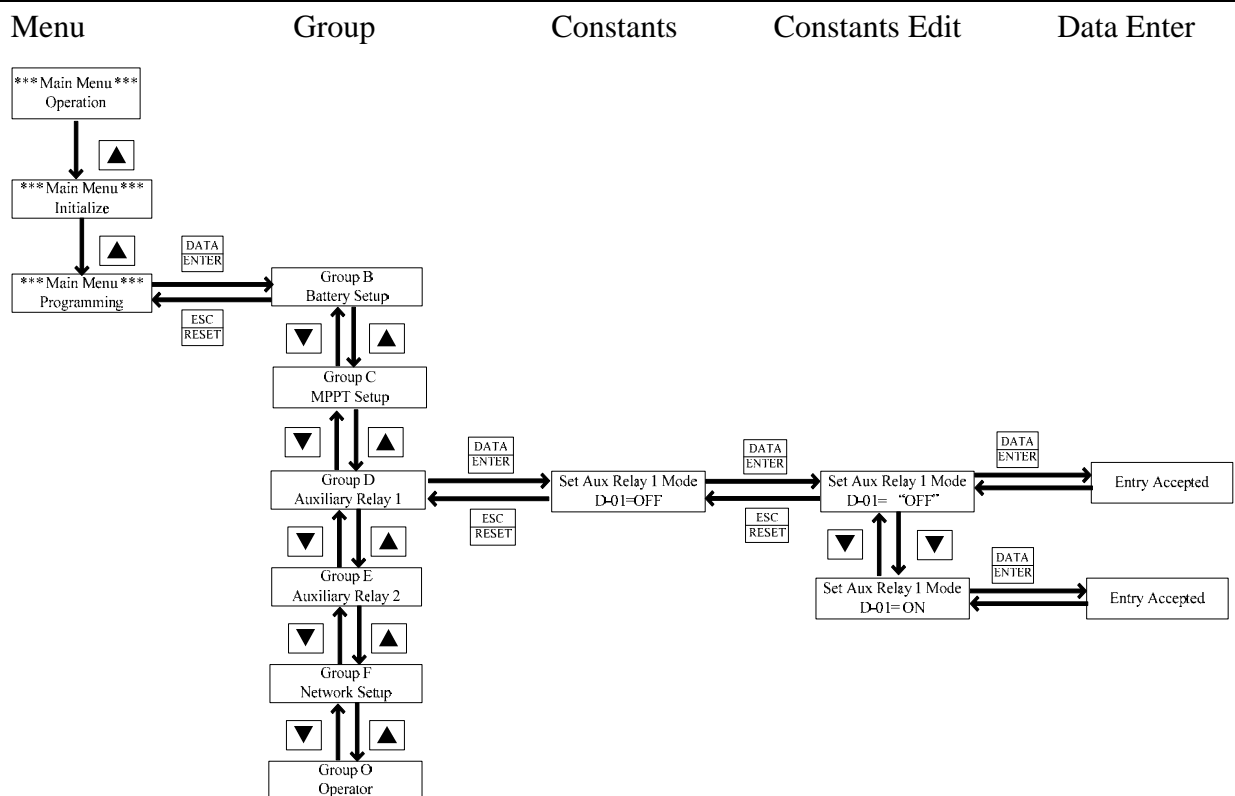

## Main Menu-Programming Group D, Auxiliary 1 ON/OFF Condition Setting

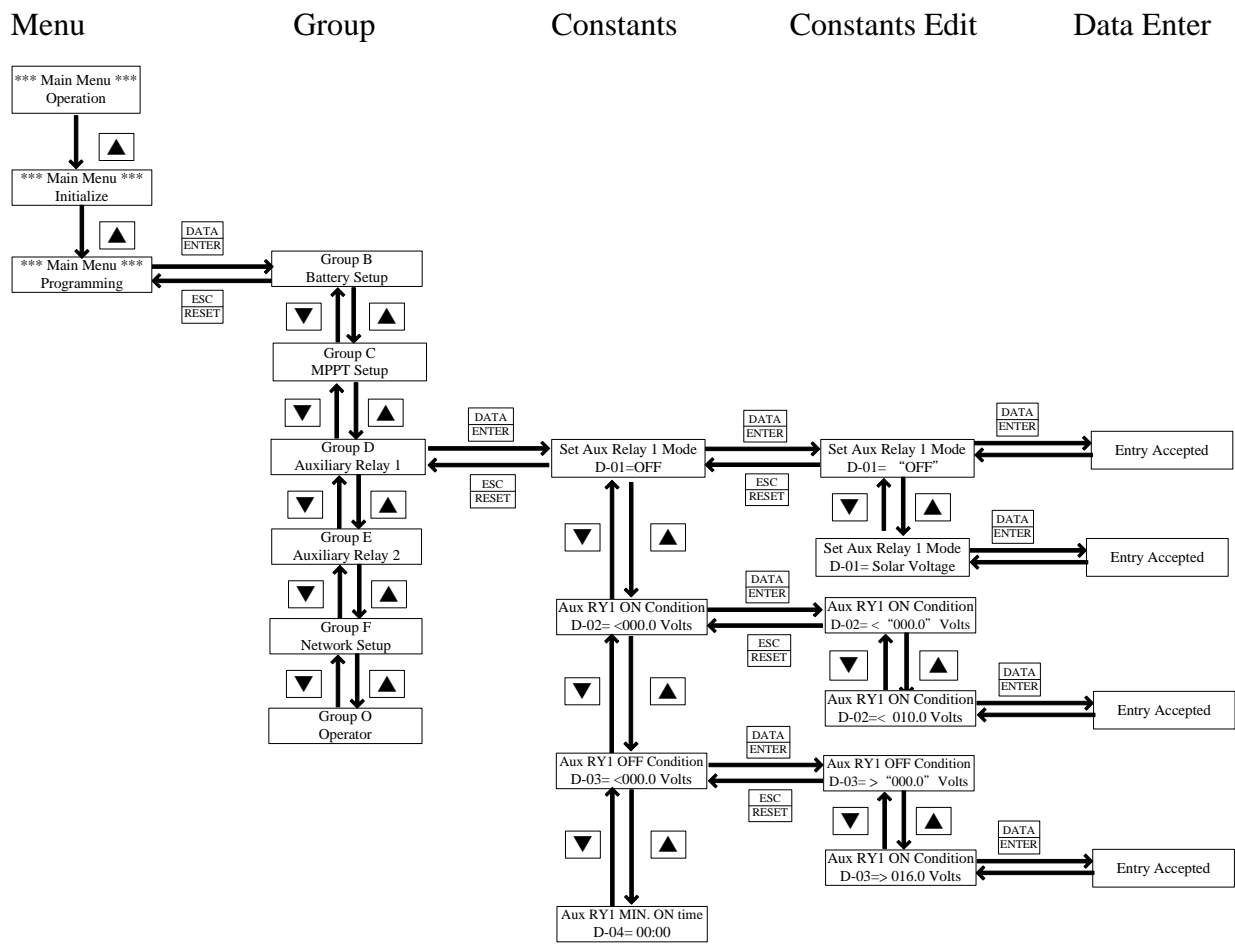

## Main Menu-Programming Group E, E-01= ON or OFF

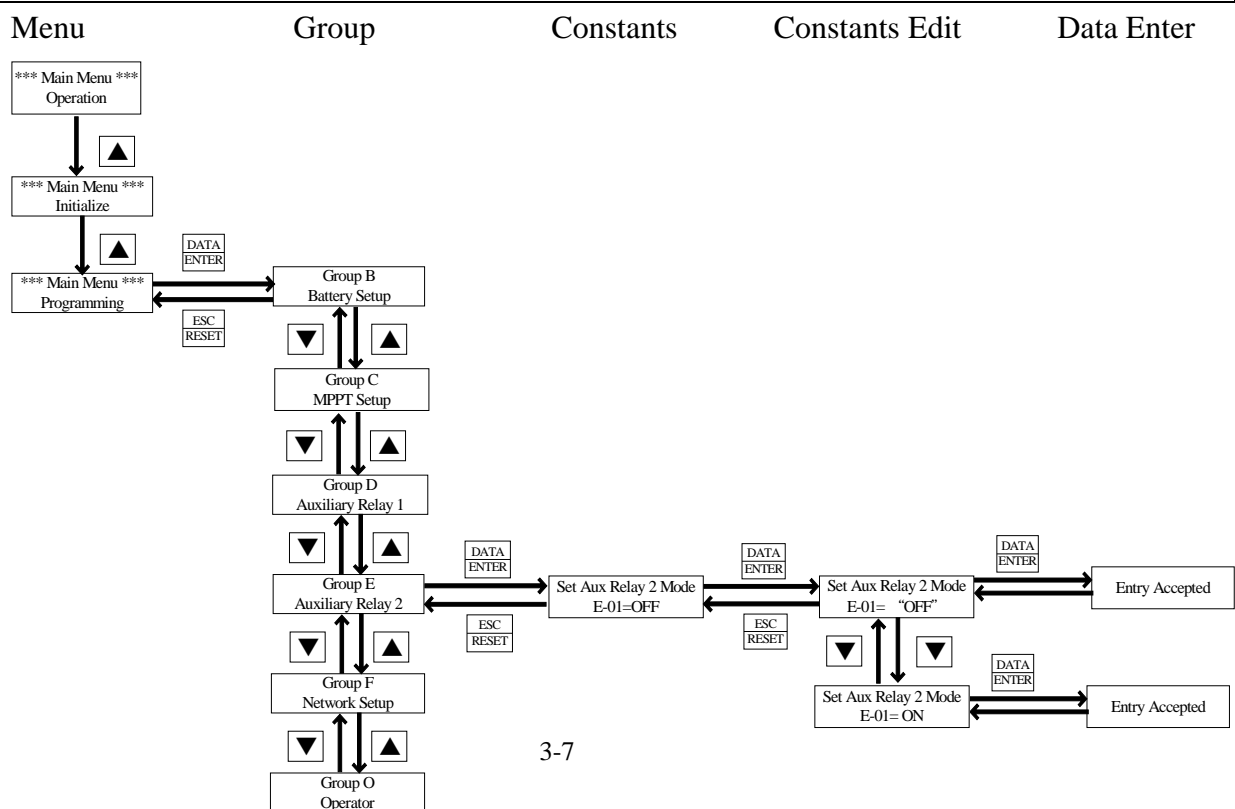

# Main Menu-Programming Group E, Auxiliary 2 ON/OFF Condition Setting

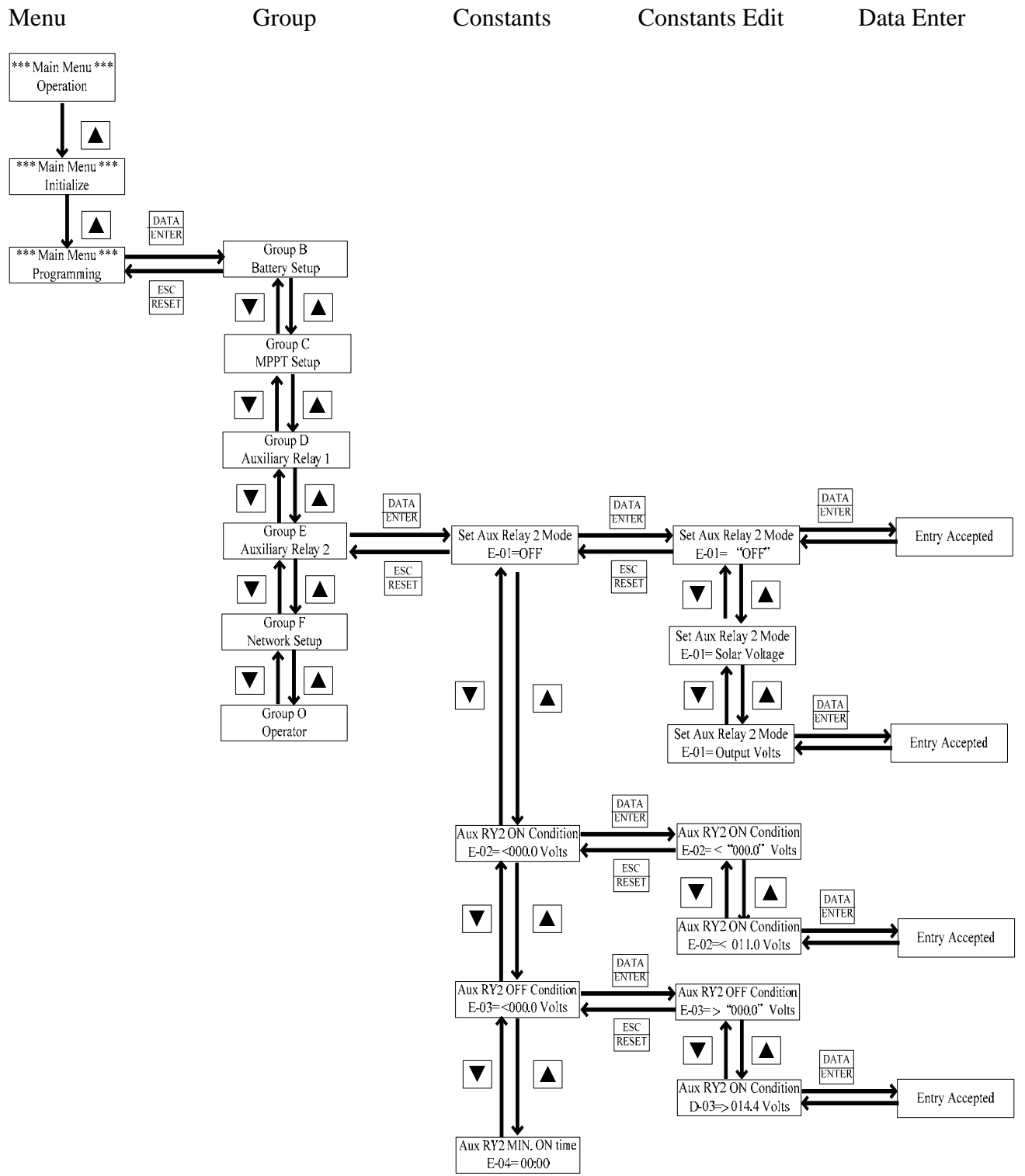

# Main Menu-Programming Group F

Menu                      Group                      Constants                      Constants Edit                      Data Enter



# Main Menu-Programming Group O

Menu                      Group                      Constants                      Constants Edit                      Data Enter

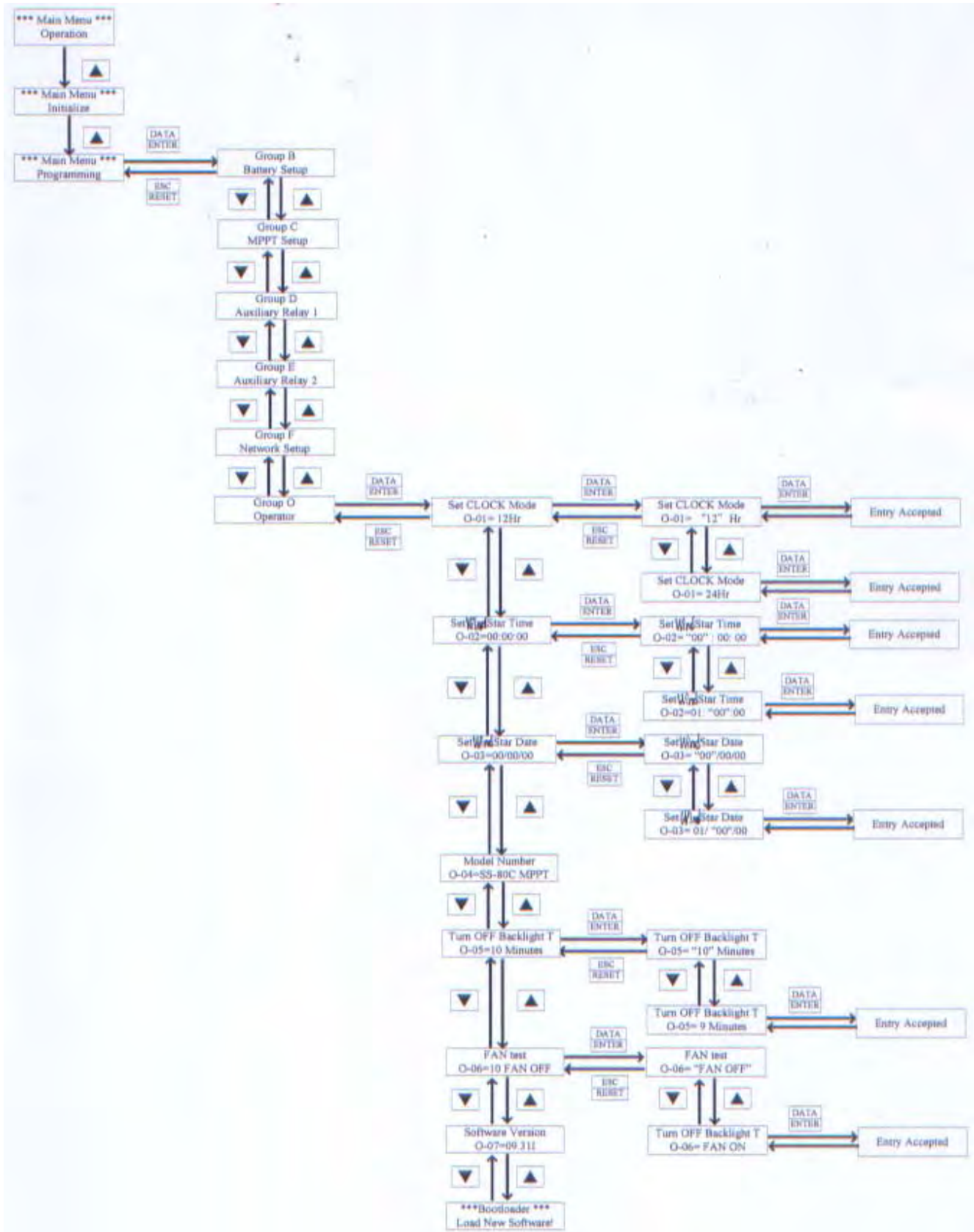

# Main Menu-Data Log

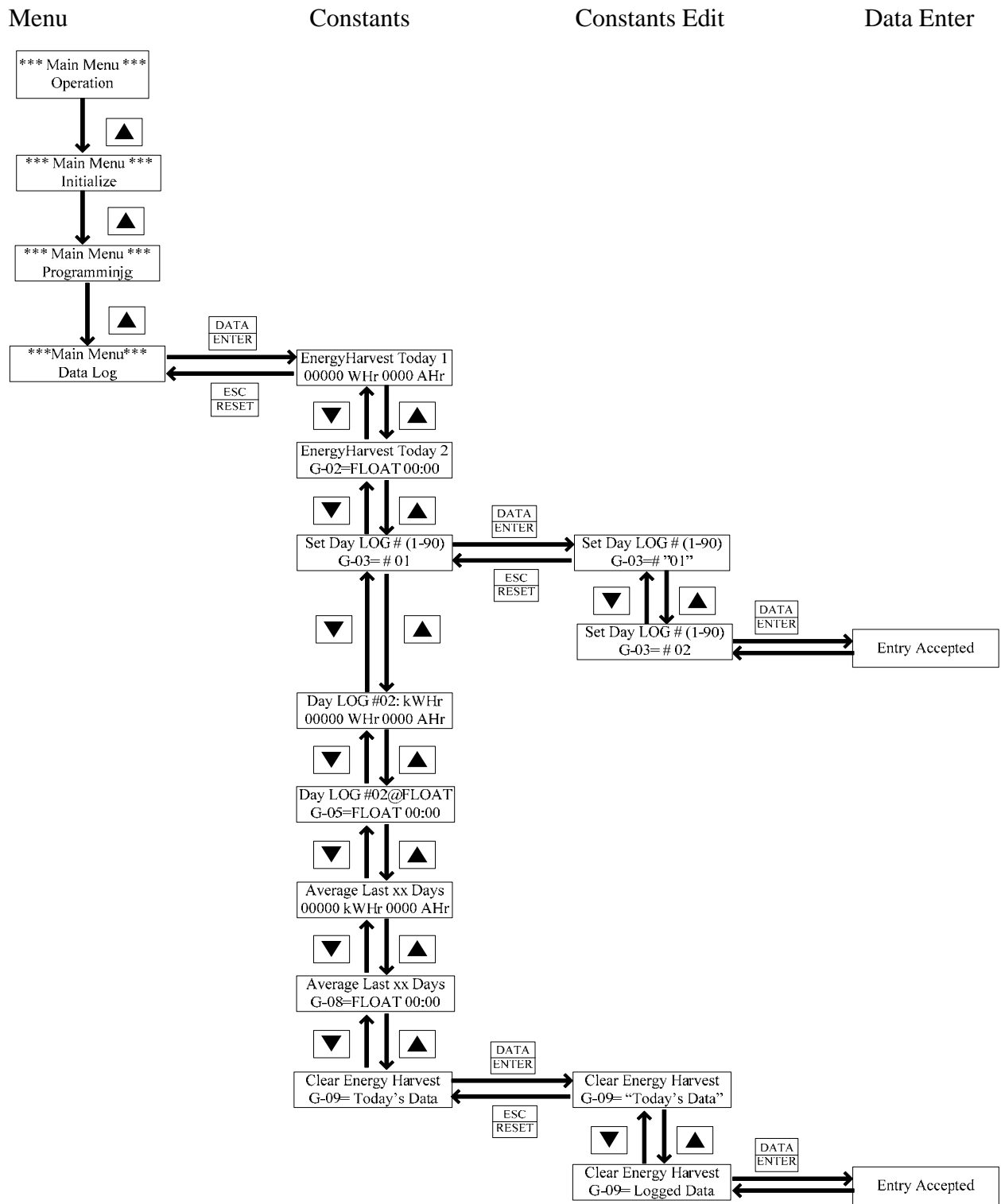

## Chapter 4 Constant List

Main Menu	Group	Constant	LCD Display	Range	Unit	Factory Setting	Remark	Page
Operation	U	U-00	IN =xxx.xV xxx.xAmps OUT =xxx.xV xxx.xAmps	—	0.1V 0.1A	—		5-1
		U-01	Input Voltage	—	0.1V	—		5-1
		U-02	Input Current	—	0.1A	—		5-1
		U-03	Output Voltage	—	0.1V	—		5-1
		U-04	Output Current	—	0.1A	—		5-1
		U-05	EnergyHarvestToday 1	—	1kWHr 1AHr	—		5-1
		U-07	EnergyHarvestToday 2	—	Hr:Min	—		5-2
		U-08	Stage of Charger	—	—	—		5-2
		U-09	WindStar Date	MM/DD/YY	—	—		5-2
		U-10	WindStar Time	Hr: Min: Sec	—	—		5-2
		U-11	WindStar Temperature	—	1°C	—		5-2
		U-12	Battery SOC	1~100%	1%	—	NOTE 1	5-2
		U-13	Battery Current	—	0.1A	—	NOTE 1	5-2
		U-14	Battery Amp Hours	—	1AHr	—	NOTE 1	5-3
		U-15	Battery Temperature	—	1°C	—	NOTE 1	5-3
		U-16	Parallel COMM Status	—	—	—	NOTE 5	5-3
		U-17	Serial Number	—	—	—		5-3
Initialize	A	A-01	Access Level	Constant Set	—	Constant Set		5-4
				Operation Only				
		A-02	Init Parameters	Preset Setting	—	No Initialize		5-4
				No Initialize				
A-03	Password 1	0~9999	1	0	NOTE 2	5-4		
A-04	Password 2	0~9999	1	0	NOTE 2	5-4		
Programming	B	Battery Setup						
		B-01	Set Battery Voltage	12/24/36/48	—	12		5-5
		B-02	Set Battery Type	GEL,	—	GEL		5-5
				FLOODED				
B-04	Set Battery Capacity	0~9990	10Ahr	—	NOTE 6	5-6		

Main Menu	Group	Constant	LCD Display	Range	Unit	Factory Setting	Remark	Page		
Programming	B	B-05	BAT. MAX Charge Amps		0~120	1A	—	NOTE 6	5-6	
		B-06	Set Absorption Volts	FLOOD-ED	13.9~15.2	0.1V	14.6		5-6	
				AGM	13.7~15.1	0.1V	14.1		5-6	
				GEL	13.6~15.1	0.1V	14.1		5-6	
		B-07	Set Absorption Time		0~ 99 Hr 59 Min	1 Min	2 Hr		5-7	
		B-08	Set Float Voltage	FLOOD-ED	12.9~14.2	0.1V	13.8		5-7	
				AGM	12.8~14.2	0.1V	13.2		5-7	
				GEL	12.8~14.1	0.1V	13.5		5-7	
		B-09	Set Equalize Voltage		12V:14.7~16.4 24V:29.4~32.8 36V:44.1~49.2 48V:58.8~65.6	0.1V	12V:15.6 24V:31.2 36V:46.8 48V:62.4	NOTE 3	5-7	
		B-10	Set MAX EQU. Time		0~ 99 Hr 59 Min	1 Min	2 Hr	NOTE 3	5-7	
		B-11	Set Days Between EQU		0~999	1 Day	OFF	NOTE 3	5-7	
		B-12	Manual Equalize		YES/NO	—	NO	NOTE 3	5-8	
	C	MPPT Setup								
		C-01	Set MPPT Type	P and O		—	P and O			5-8
				Scan and Hold						
				Percentage						
				Hold Input V						
		C-02	Set Scan Frequency		1~4Hr	1 Min	1 Hr	NOTE 4	5-8	
		C-03	Set Percentage VOC		0~100	1%	80	NOTE 4	5-9	
	C-04	Percentage EveryTime		1~4Hr	1 Min	1 Hr	NOTE 4	5-9		
C-05	Set Hold Input Volts		0~240	0.1V	—	NOTE 4 NOTE 6	5-9			

Main Menu	Group	Constant	LCD Display	Range	Unit	Factory Setting	Remark	Page
Programming	D	Auxiliary Relay 1						
		D-01	Set Aux Relay 1 Mode	OFF, ON, Wind Voltage, Output Volts, Battery Volts, OUT Current, BATT Current, WindStar Temp. Battery Temp. WindStar Time Battery SOC, Output Volts	—	OFF		5-9
		D-02	Aux RY1 ON Condition	See Below	See Below	See Below		5-10
			When D-01= Wind Voltage	0~240	0.1V	0		5-10
			When D-01=Output Volts	0~64	0.1V	0		5-10
			When D-01=Battery Volts	0~64	0.1V	0		5-10
			When D-01=OUT Current	0~120	1A	0		5-10
			When D-01=BATT Current	-500~500	1A	0		5-10
			When D-01=WindStar Temp.	-20~100	1°C	0		5-10
			When D-01=Battery Temp.	-20~100	1°C	0		5-10
			When D-01=WindStar Time	00~23 Hr 00~59 Min	1 Min	0		5-10
			When D-01=Battery SOC	0~100	1%	0		5-10
		D-03	AuxRY1 OFF Condition	See Below	See Below	See Below		5-11
			When D-01= Wind Voltage	0~240	0.1V	0		5-11
			When D-01=Output Volts	0~64	0.1V	0		5-11
			When D-01=Battery Volts	0~64	0.1V	0		5-11
			When D-01=OUT Current	0~120	1A	0		5-11
			When D-01=BATT Current	-500~500	1A	0		5-11
			When D-01=WindStar Temp.	-20~100	1°C	0		5-11
			When D-01=Battery Temp.	-20~100	1°C	0		5-11

Main Menu	Group	Constant	LCD Display	Range	Unit	Factory Setting	Remark	Page	
Programming	D	D-03	When D-01=WindStar Time	00~23 Hr 00~59 Min	1 Min	0		5-11	
			When D-01=Battery SOC	0~100	1%	0		5-11	
		D-04	Aux RY1 MIN. ON time	0~23 Hr, 0~59Min	1 Min	0		5-11	
	E	Auxiliary Relay 2							
		E-01	Set Aux Relay 2 Mode	OFF, ON, Wind Voltage, Output Volts, Battery Volts, OUT Current, BATT Current, WindStar Temp. Battery Temp. WindStar Time, Battery SOC, Output Volts	—	OFF			5-12
		E-02	Aux RY2 ON Condition	See Below	See Below	See Below			5-12
			When E-01= Wind Voltage	0~240	0.1V	0			5-12
			When E-01=Output Volts	0~64	0.1V	0			5-12
			When E-01=Battery Volts	0~64	0.1V	0			5-12
			When E-01=OUT Current	0~120	1A	0			5-12
			When E-01=BATT Current	-500~500	1A	0			5-12
			When E-01=WindStar Temp.	-20~100	1°C	0			5-12
			When E-01=Battery Temp.	-20~100	1°C	0			5-12
			When E-01=WindStar Time	00~23 Hr 00~59 Min	1 Min	0			5-12
		When E-01=Battery SOC	0~100	1%	0			5-12	
		E-03	AuxRY2 OFF Condition	See Below	See Below	See Below			5-12
			When E-01= Wind Voltage	0~240	0.1V	0			5-12
			When E-01=Output Volts	0~64	0.1V	0			5-12
			When E-01=Battery Volts	0~64	0.1V	0			5-12

Main Menu	Group	Constant	LCD Display	Range	Unit	Factory Setting	Remark	Page	
Programming	E	E-03	When E-01=OUT Current	0~120	1A	0		5-12	
			When E-01=BATT Current	-500~500	1A	0		5-12	
			When E-01=WindStar Temp.	-20~100	1°C	0		5-12	
			When E-01=Battery Temp.	-20~100	1°C	0		5-12	
			When E-01=WindStar Time	00~23 Hr 00~59 Min	1 Min	0		5-12	
			When E-01=Battery SOC	0~100	1%	0		5-12	
		E-04	Aux RY2 MIN. ON time	00~23 Hr 00~59 Min	1 Min	0		5-12	
	F	Parallel Setup							
		F-01	WindStarParallel MODE	Standalone, Master, Slave	—	Stand- alone			5-12
		F-02	WindStarParallel Addr	2~16	—	2	NOTE 5		5-12
	O	Operator							
		O-01	Set CLOCK Mode	12/24 Hr	—	12			5-13
		O-02	Set WindStar Time	Hr: Min: Sec	—	—			5-13
		O-03	Set WindStar Date	MM/DD/YY	—	—			5-13
		O-04	Model Number	—	—	SS-xx C MPPT	NOTE 6		5-13
		O-05	Turn OFF Backlight T	0~10	1 Min	10			5-13
		O-06	FAN Test	ON/OFF	—	OFF			5-14
		O-07	Software Version	—	—	9.31I			5-14
		O-08	***Bootloader***	—	—	—			5-14
	Data Log	G	G-01	EnergyHarvestToday 1	—	kWHr Ahr	—		5-14
			G-02	EnergyHarvestToday 2	—	Hr:Min	—		5-14
			G-03	Set Day LOG # (1-90)	1~90	1 Day	—		5-14
			G-04	Day LOG # : kWHr	—	kWHr Ahr	—		5-15
G-05			Day LOG # @ FLOAT	—	Hr:Min	—		5-15	
G-07			Average Last Days xxxxx kWHr xxxxx Ahr	—	kWHr Ahr	—		5-15	
G-08			Average Last Days FLOAT xx : xx	—	Hr:Min	—		5-15	

Data Log	G	G-09	Clear Energy Harvest	Today's Data Logged Data	—	Today's Data		5-16
----------	---	------	----------------------	-----------------------------	---	-----------------	--	------

NOTE 1 (U-12, U-13, U-14, U-15)

Battery SOC, Battery Current and Battery Amp Hours will only be visible when terminal BVS (Battery Voltage Sensing) is connected to the battery and will only be active when using an optional 50mv/500amp external shunt.

Battery Temperature will only be visible when terminal BVS (Battery Voltage Sensing) is connected to the battery and will only be active when using a Battery Temperature Sensor (BTS-3).

**※ These four constants will only be displayed when the terminal BVS (Battery Voltage Sensing) is wired to the battery. To show the precise values, an optional 50mv/500amp external shunt is needed for U-12, U-13, U-14 and a Battery Temperature Sensor is needed for U-15.**

NOTE 2 (A-03, A-04)

These two constants are reserved for the authorized distributor or technician to lock the constants operation.

**Lock the constants setting**

1. Finish setting all the programmable constants to the desired values.
2. Change A-01=Operation Only, factory setting is A-01=Constants Set.
3. Use UP key to go to A-03 to enter the password 1 (max. 4 digits)
4. Go to any display of A-xx and press DOWN key and hold it, then press ESC key at the same time till A-04 constant occurs.
5. Enter the desired password 2 (max. 4 digits) into A-04. Make sure the password 1 in A-03 must be different from the password 2 in A-04. Finally, press ENTER key to finish “lock” setting.

Above procedure completes locking the constants setting and no more programming selection would appear. A-01 would only display Operation only and would not display Constants Set.

**Unlock the constants setting**

1. Enter the password in A-03 to be exactly the same as the one earlier set in A-04
2. When the password in A-03 matches the one earlier set in A-04, the unlocking is completed. A-01=Constants Set would appear again for programming.

NOTE 3 (B-09, B-10, B-11, B-12)

These constants are only displayed if Flooded is selected as battery type (B-02).

NOTE 4 (C-02, C-03, C-04, C-05)

C-02 is only displayed if P and O or Scan and Hold is selected as MPPT Type (C-01).

C-03 and C-04 are only displayed if Percentage is selected as MPPT Type (C-01).

C-05 is only displayed if Hold Input V is selected as MPPT Type (C-01).

NOTE 5 (U-16, F-02)

U-16 and F-02 are only displayed if Slave is selected as WindStar Network MODE (F-01).

NOTE 6 (B-04, B-05, C-05, O-04)

The factory settings of the listed constants are dependent on the different model numbers.

Constant	LCD Display	WS-120CX MPPT Factory Setting	WS-80CX MPPT Factory Setting
B-04	Set Battery Capacity	2400 Ahr	1600Ahr
B-05	Bat. MAX Charge Amps	120A	80A
C-05	Set Hold Input Volts	240Vdc	240Vdc
O-04	Model Number	WS-120CX MPPT	WS-80CX MPPT

Constant	LCD Display	WS-50CX MPPT Factory Setting
B-04	Set Battery Capacity	1000 Ahr
B-05	Bat. MAX Charge Amps	50A
C-05	Set Hold Input Volts	240Vdc
O-04	Model Number	WS-50CX MPPT

## Chapter 5 Programming Constants

\*\*\* Main Menu\*\*\*  
Operation

**U-00: IN=xxx.xV xxx.xAmps  
OUT=xxx.xV xxx.xAmps**

- Use Constant U-00 to monitor the power coming in from the Wind Turbine in Volts and Amps. The second line displays the power going out of the WINDSTAR MPPT, it also displays in Volts and Amps.
- In most installations there will be a difference between incoming volts and outgoing volts. This reflects the flexibility of the WINDSTAR MPPT with respect to Wind Turbine input voltage vs. battery voltage. Incoming and outgoing amps will also differ because they are the result of dividing watts (a constant) by volts.

**U-01: Input Voltage**

- This screen displays the input voltage value coming from the Wind Turbine in Volts.

**U-02: Input Current**

- This screen displays the input current value coming from the Wind Turbine in Amps.

**U-03: Output Voltage**

- This screen displays the power going out of the WINDSTAR MPPT in Volts.

**U-04: Output Current**

- This screen displays the power going out of the WINDSTAR MPPT in Amps.

#### U-05: EnergyHarvest Today 1

- This screen displays how much the wind energy was harvested “Today” in kWhr and AHr.

#### U-07: EnergyHarvest Today 2

- This screen displays how much time the charger was in Float mode “Today” in Hour:Minute.

#### U-08: Stage of Charger

- This screen displays the charging stage of WINDSTAR MPPT. The possible values are Charger Off, Charger Start, BULK Stage, ABSORP Stage, FLOAT Stage, Charger MPPT, Charger Stop, EQUALZ Stage.

#### U-09: WindStar Date

- This screen displays the date according to the setting of initialization stage. The display format is MM/DD/YY.

#### U-10: WindStar Time

- This screen displays the time according to the setting of initialization stage.

#### U-11: WindStar Temperature

- This screen displays the temperature detected in WINDSTAR MPPT Battery Charger.

#### U-12: Battery SOC

- This screen displays the stage of charge (SOC) as a percentage of fully charged. SOC will only be visible when terminal BVS (Battery Voltage Sensing) is connected to the battery and will only be active when using an optional 50mv/500amp external shunt.
- ※ **U-12 will only be displayed when the terminal BVS (Battery Voltage Sensing) is wired to the battery. To show the precise values, an optional 50mv/500amp external shunt is needed.**

### U-13: Battery Current

- This screen displays the battery current in Amps. Battery Current will only be visible when terminal BVS (Battery Voltage Sensing) is connected to the battery and will only be active when using an optional 50mv/500amp external shunt.
- ※ **U-13 will only be displayed when the terminal BVS (Battery Voltage Sensing) is wired to the battery. To show the precise values, an optional 50mv/500amp external shunt is needed.**

### U-14: Battery Amp Hours

- This screen displays the battery capacity in AHr (Amp Hours). Battery Amp Hours will only be visible when terminal BVS (Battery Voltage Sensing) is connected to the battery and will only be active when using an optional 50mv/500amp external shunt.
- ※ **U-14 will only be displayed when the terminal BVS (Battery Voltage Sensing) is wired to the battery. To show the precise values, an optional 50mv/500amp external shunt is needed.**

### U-15: Battery Temperature

- This screen displays the battery temperature in °C. Battery Temperature will only be visible when Battery Voltage Sensor is connected and will only be active when using a Battery Temperature Sensor (BTS-3).
- ※ **U-15 will only be displayed when the terminal BVS (Battery Voltage Sensing) is wired to the battery. To show the precise values, a Battery Temperature Sensor (BTS-3) is needed to be wired to terminal BTS.**

### U-16: Parallel COMM Status

- This screen displays the communication status between Master unit and Slave units. U-16 is only displayed when Slave is selected as WINDSTAR Network MODE (F-01).
- When the communication is successful, the screen displays SLAVE UNIT. When the communication fails, then screen displays NETWORK ERROR.

## U-17: Serial Number

- This screen displays the unit serial number. It is useful when contacting Rich Electric Technical Support.

\*\*\* Main Menu\*\*\*  
Initialize

## A-01: Access Level

- Use Constant A-01 to select the user constant access level.  
This level determines which user constants can be changed and displayed.

### Settings:

#### **A-01=Constant Set (Factory Setting)**

This setting allows all user constants to be changed and displayed.

#### **A-01=Operation Only**

This setting allows the “Operation” and “Initialize” to be changed or displayed.

## A-02: Init Parameters

- Use Constant A-02 to initialize the user constants.
- When initialized, the user constants will return to their factory preset values. You should normally record the setting of any constants that are changed from factory presets.

### Settings:

#### **A-02=Preset Setting**

This setting allows to initialize the user constants to factory settings.

#### **A-02=No Initialize (Factory Setting)**

This setting does not initialize any user constants.

## A-03: Password 1

## A-04: Password 2

- These two constants are reserved for the factory to test and set the functions.

- Users are not allowed to set these two constants.

### **Lock the constants setting**

1. Finish setting all the programmable constants to the desired values.
2. Change A-01=Operation Only, factory setting is A-01=Constants Set.
3. Use UP key to go to A-03 to enter the password 1 (max. 4 digits)
4. Go to any display of A-xx and press DOWN key and hold it, then press ESC key at the same time till A-04 constant occurs.
5. Enter the desired password 2 (max. 4 digits) into A-04. Make sure the password 1 in A-03 must be different from the password 2 in A-04. Finally, press ENTER key to finish “lock” setting.

Above procedure completes locking the constants setting and no more programming selection would appear. A-01 would only display Operation only and would not display Constants Set.

### **Unlock the constants setting**

1. Enter the password in A-03 to be exactly the same as the one earlier set in A-04
2. When the password in A-03 matches the one earlier set in A-04, the unlocking is completed. A-01=Constants Set would appear again for programming.

\*\*\* Main Menu\*\*\*  
Programming

Group B  
Battery Setup

### **B-01: Set Battery Voltage**

- During initialization of WINDSTAR MPPT, it will detect and ask the installer to confirm the battery voltage found is correct. In almost all circumstance the WINDSTAR MPPT will correctly detect battery voltage.
- Use Constant B-01 to change the battery voltage if the battery voltage displayed by the WINDSTAR MPPT is different from the installed batteries. The selection range of the battery voltage is 12V (Factory Setting), 24V, 36V and 48V.

### **B-02: Set Battery Type**

- Use UP or DOWN keys to allow the installer to change what type of batteries it

is connected to (Flooded, Gel, AGM) SUNSTAR MPPT. The default “BATTERY TYPE” is GEL

- Please be sure to select the type which matches the system’s batteries. This setting controls battery charging voltages in B-06 and B-08.

**B-04: Set Battery Capacity**

- This setting controls battery charging amperages and other settings. The factory setting for CAPACITY is 2400 amp hours for WS-120CX MPPT, 1600 amp hours for WS-80CX MPPT and 1000 amp hours for WS-50CX MPPT.
- At full output capacity a WS-80CX MPPT can deliver 80 amps to a battery, this amount of amperage (current) is equal to the C/10 (capacity divided by ten) rate of a 1600 amp hour battery and, as such meets most manufacturers recommendations for minimum Wind charging capacity.
- In applications with battery banks under 1600 amp hours it is recommended to lower the Maximum Charge Rate setting from the default 80 amps to the C10 rate of the battery bank.

**B-05: BAT. MAX Charge Amps**

- Use Constant B-05 to allow the installer to limit the maximum charge amps allowed to the batteries. The factory setting is 120 amps (WS-120CX MPPT), 80 amps (WS-80CX MPPT) and 50 amps (WS-50CX MPPT).

**B-06: Set Absorption Volts**

- Use Constant B-06 to adjust the Absorption voltages. The default values are based on the battery type and capacity selected. It is not advisable to change default settings unless advised by the battery manufacturer or supplier.

Battery Type	Absorption Volts Range	Factory Setting
FLOODED	13.9V~15.2V	14.6V
AGM	13.7V~15.1V	14.1V
GEL	13.6V~15.1V	14.1V

※ The above values are based on 12V system. The values x 2 are for 24V

system; the values x 3 are for 36V system and the values x 4 are for 48V system.

- WINDSTAR MPPT series will charge at the Absorption voltage and at the length of time before switching to float mode.

**B-07: Set Absorption Time**

- Use Constant B-07 to adjust the length of Absorption time. The factory setting is 2 hours (displayed as 02:00).

**B-08: Set Float Voltage**

- Use Constant B-08 to adjust the Float voltages. The default set values are based on the battery type and capacity selected. It is not advisable to change default settings unless advised by the battery manufacturer or supplier.

Battery Type	Float Volts Range	Factory Setting
FLOODED	12.9V~14.2V	13.8V
AGM	12.8V~14.2V	13.2V
GEL	12.8V~14.1V	13.5V

※ The above values are based on 12V system. The values x 2 are for 24V system; the values x 3 are for 36V system and the values x 4 are for 48V system.

**B-09: Set Equalize Voltage**

- This constant is only displayed if Flooded is selected as battery type (B-02). Use Constant B-09 to select the Equalize voltages. The default values are based on the battery voltage and capacity selected. It is not recommended to change default settings unless advised so by the battery manufacturer or supplier.

Battery Type	Battery Voltage	Equalization Volts Range	Factory Setting
FLOODED	12V	14.7V~16.4V	15.6V
	24V	29.4V~32.8 V	31.2V
	36V	44.1V~49.2V	46.8V
	48V	58.8V~65.6V	62.4V

### **B-10: Set MAX EQU. Time**

- This constant is only displayed if Flooded is selected as battery type (B-02). Use Constant B-10 to select the time of equalization time. The factory setting is 2 hours (displayed as 02:00).

### **B-11: Set Days Between EQU**

- This constant is only displayed if Flooded is selected as battery type (B-02). Use Constant B-11 to select the number of days between equalization charges. The factory setting is OFF.

### **B-12: Manual Equalize**

- This constant is only displayed if Flooded is selected as battery type (B-02). Use Constant B-12 to choose between manual and automatic equalization settings.
- Press ENTER key to select Yes for manual equalization and then it will display the Equalize voltage set in B-09 and the Max. EQU time set in B-10. Press ENTER key again to start the manual equalization.
- ※ During equalization, only ESC key is active to leave the equalization process screen.

After the manual equalization starts, BAT displays Battery voltage. Battery temperature and Equalizing blinks in return. CHARGE displays charging current. Finally, the remaining time for equalization charge is counted down.

WARNING: Before the manual equalization is selected, WINDSTAR MPPT should be connected to Battery Temperature Sensor (BTS-3). If it is not connected to BTS-3, “Warning, Bat. Sr Not Connected” is displayed.

- Press ESC key to select No to return to the display of Group B.

Group C MPPT Setup
-----------------------

### **C-01: Set MPPT Type**

- Use Constant C-01 to set up the MPPT type: P and O, Scan and Hold, Percentage, Hold Input V. The factory setting is P and O.

#### **C-02: Set Scan Frequency**

- This constant is only displayed if P and O or Scan and Hold is selected as MPPT Type (C-01).
- The scan frequency is settable from 1 minute to 4 hours and the factory setting is 1 hour. Press the UP and DOWN key to increase or decrease the length of time.
- P and O (Perturb and Observe) will run a full scan at the set time interval (frequency) and then do P and O scans at shorter intervals in between.
- Scan and Hold will run a full scan at the set time interval (frequency) and then hold the resultant MP until the next interval. This is also settable from 1 minute to 4 hours; factory is 1 hour.

#### **C-03: Set Percentage VOC**

- This constant is only displayed if Percentage is selected as MPPT Type (C-01).
- Percentage measures the VOC at the set time interval and calculates the operating  $V_{mp}$  based on the percentage set. The percentage set point can be from 0 – 100% and factory setting is 80%.

#### **C-04: Set Percentage EveryTime**

- This constant is only displayed if Percentage is selected as MPPT Type (C-01).
- When Percentage measure the VOC, the time interval can be set and time is 1 minute to 4 hours. Factory setting is 1 hour.

#### **C-05: Set Hold Input Volts**

- This constant is only displayed if Hold Input V is selected as MPPT Type (C-01).
- Hold Input Voltage will regulate based on the input voltage set (0-240V) for WS-120CX MPPT, WS-80CX MPPT and WS-50CX MPPT, based on the Wind Turbine type. The output current will be based on that voltage.

Group D  
Auxiliary Relay 1

### D-01: Set Aux Relay 1 Mode

- The Auxiliary Relays are useful for functions such as turning a generator on or off at low battery voltage or load change, turning on an external fan when battery temperature increases, or shedding certain loads at specific times. Additional functions will be added in the future.
- Use Constant D-01 to select the Auxiliary Relay 1 mode and what it is based on.
- Auxiliary Relay 1 Mode includes OFF, ON, Wind Voltage, Output Voltage, Battery Voltage (only displayed and active when terminal BVS is connected to the battery), Output Current, Battery Current (only active when terminal BCS is connected with a Shunt 50mV, 500Amp), WindStar Temperature, Battery Temperature (only active when terminal BTS is connected with a Battery Temperature Sensor, BTS-3), WindStar Time and Battery State of Charge(only displayed when terminal BCS is connected with Shunt 500Amp, 50mV). The factory setting is OFF.
- D-02, D-03 and D-04 will not be displayed, when D-01 is set to be ON or OFF.

### D-02: Aux RY1 ON Condition

- According to 9 selectable modes in D-01, use Constant D-02 to set the condition to activate the Auxiliary Relay 1 to be ON.
- The displayed setting range of D-02 will change to less than or greater than (< or >) depending on if D-02 or D-03 is higher or lower value. This allows setting on either a rising or falling voltage.
- Once entering the D-02, use UP and DOWN keys to increment and decrement the values.

Aux RY1 ON Condition	Setting Range of D-02	Setting Unit
When D-01= Wind Voltage	< or > 0~240V	0.1V
When D-01=Output Volts	< or > 0~64V	0.1V
When D-01=Battery Volts	< or > 0~64V	0.1V
※ Battery Voltage is only displayed and active when terminal BVS is connected to the battery.		
When D-01=OUT Current	< or > 0~120A	1A
When D-01=BATT Current	< or > -500~500A	1A
※ Battery Current is only active when terminal BCS is connected with a Shunt 50mV, 500Amp.		
※ The values may be positive or negative as this input reads load current as		

well as charge current.		
When D-01=WindStar Temp.	< or > -20~100°C	1°C
When D-01=Battery Temp.	< or > -20~100°C	1°C
※ Battery Temperature is only active when terminal BTS is connected with a Battery Temperature Sensor (BTS-3).		
When D-01=WindStar Time	< or > 00~23 Hr 00~59 Min	1 Min
When D-01=Battery SOC	< or > 0~100%	1%
※ Battery SOC is only active when terminal BCS is connected with a Shunt 50mV, 500Amp.		

### D-03: Aux RY1 OFF Condition

- According to 9 selectable modes in D-01, use Constant D-03 to set the condition to activate the Auxiliary Relay 1 to be OFF.
- The displayed setting range of D-03 will change to less than or greater than (< or >) depending on if D-02 or D-03 is higher or lower value. This allows setting on either a rising or falling voltage.
- Once entering the D-03, use UP and DOWN keys to increment and decrement the values.

Aux RY1 OFF Condition	Setting Range of D-03	Setting Unit
When D-01= Wind Voltage	< or > 0~240V	0.1V
When D-01=Output Volts	< or > 0~64V	0.1V
When D-01=Battery Volts	< or > 0~64V	0.1V
※ Battery Voltage is only displayed and active when terminal BVS is connected to the battery.		
When D-01=OUT Current	< or > 0~120A	1A
When D-01=BATT Current	< or > -500~500A	1A
※ Battery Current is only active when terminal BCS is connected with a Shunt 50mV, 500Amp. ※ The values may be positive or negative as this input reads load current as well as charge current.		
When D-01=WindStar Temp.	< or > -20~100°C	1°C
When D-01=Battery Temp.	< or > -20~100°C	1°C
※ Battery Temperature is only active when terminal BTS is connected with a Battery Temperature Sensor (BTS-3).		

When D-01=WindStar Time	< or > 00~23 Hr 00~59 Min	1 Min
When D-01=Battery SOC	< or > 0~100%	1%
※ Battery SOC is only active when terminal BCS is connected with a Shunt 50mV, 500Amp.		

**D-04: Aux RY1 MIN. ON time**

- Use Constant D-04 is to set the minimum time that the relay can remain active.
- The minimum time is set to avoid the difference of the values set in D-02 and D-03 is so small to cause the damage on the relay due to the high frequency of relay action between ON and OFF.

Group E  
Auxiliary Relay 2

**E-01: Set Aux Relay 2 Mode**  
**E-02: Aux RY2 ON Condition**  
**E-03: Aux RY2 OFF Condition**  
**E-04: Aux RY2 MIN. ON time**

※ The functions and the settings of Auxiliary Relay 2 are exactly the same as those of Auxiliary Relay 1 so please refer to above Group D, Auxiliary Relay 1 description.

Group F  
Parallel Setup

**F-01: WindStarParallel MODE**

- Use Constant F-01 to set up WINDSTAR MPPT Network. Each WINDSTAR MPPT in parallel requires a mode and address entry.
- The Mode choices are:

Setting	Usage
Standalone	Used when there is only one WINDSTAR MPPT with a Remote Display connected.
Master	Used to assign the network master (this is the WINDSTAR MPPT that connects to the shunt).

Slave	<p>Assigns up to 15 additional WINDSTAR MPPT slave units. The first WINDSTAR MPPT is assigned as master and the rest of units in network are slaves. The network address will be assigned to each slave unit in F-02.</p>
-------	---

### **F-02: WindStarParallel Addr**

- A WINDSTAR MPPT assigned as Master or Standalone is always addressed 01 automatically so the address assignment in F-02 is only available for the slave units.
- The maximum slave address number is 16 and the factory setting is 2.

<p>Group O Operator</p>
-----------------------------

### **O-01: Set CLOCK Mode**

- This is the same display as in the initialization setup of battery.
- Use Constant O-01 to change and select the hour format displayed between 12 Hour and 24 Hour. Factory setting is 12 Hour Format.
- When 12 Hour is selected, AM and PM indication will be shown in O-02.

### **O-02: Set WindStar Time**

- This is the same display as in the initialization setup of battery.
- When 12 Hour format is selected in O-01, AM and PM indication will be shown.
- Press ENTER to start to edit the Hour:Minute: Second number and press UP and DOWN key to increment or decrement the values.

### **O-03: Set WindStar Date**

- This is the same display as in the initialization setup of battery.
- Press ENTER key to start to edit the MM/DD/YY and press UP and DOWN key to increment or decrement the values.

### **O-04: Model Number**

- The model number of the unit is displayed.

#### **O-05: Turn OFF Backlight T**

- Use Constant O-05 to set the operation of the LCD backlight. Since the backlight consumes a fair amount of quiescent current, it is recommended that the on time be as short as possible.
- Press ENTER key to enter the setting and press UP and DOWN key to turn off from NEVER (always on) or 1 to 10 minutes in 1 minute increments.

**Note:** When the backlight turns off, pressing any key will turn it back to U-00 display screen.

#### **O-06: Fan Test**

- Use Constant O-06 to test if the fan can be forced to be ON or OFF.
- When FAN ON is selected, the fan test is conducted as the O-06 screen remains. Once the screen leaves O-06, it will stop the test running.

#### **O-07: Software Version**

- The software version displayed is important and useful when contacting Rich Electric Technical Support.

#### **O-08: \*\*\*Bootloader\*\*\***

- This is the Bootloader initiation display. It is only used to update the firmware.

\*\*\* Main Menu\*\*\*  
Data Log

#### **G-01: EnergyHarvest Today 1**

- This screen displays how much the wind energy was harvested “Today” in kWhr and AHr unit.

#### **G-02: EnergyHarvest Today 2**

- This screen displays how much time the charger was in Float mode “Today”.
- It is valuable to know that the charger enters Float mode because this is a clear indication that the batteries have been fully recharged. If the value displayed in “G-02=FLOAT ” is consistently 00.00 Hr, it means that the Wind Turbine is not sufficiently sized to keep up with the load. Use a generator for additional battery charging, reduce loads, or expand the Wind Turbine to ensure that batteries are fully recharged. For maximum service life batteries should be fully recharged at least once every five to ten days.

**G-03: Set Day LOG# (1-90)**

- Use G-03 to set the Day Log number to display the energy harvested from Wind Turbine (shown in G-04 and G-05) by WINDSTAR MPPT over a period of time.
- If it is selected as #2 displays past power production since the last power cycle (or up to 90 days previous) along with the date of day before the current date. Use UP and DOWN keys to select the date by one and the energy harvested on the date shown is displayed in G-04.

**G-04: Day LOG# :kWHr**

- This screen displays how much the wind energy was harvested in kWHr and AHr according to the selected day shown in G-03.

**G-05: Day LOG# @FLOAT**

- This screen displays how much time the charger was in Float mode according to the selected day shown in G-03.

**G-07: Average Last Days  
xxxxx kWHr xxxx AHr**

- This screen shows the average power produced over the past cumulative days as both in kWHr and AHr.

**G-08: Average Last Days  
FLOAT xx : xx**

- This screen displays how much average time the charger was in Float mode in

the past cumulative days, shown in Hour: Minute.

#### **G-09: Clear Energy Harvest**

- Use Constant G-09 to clear Today's Data or all the Logged Data.
- Press ENTER key and use UP and DOWN keys to select between Today's Data and Logged Data and then press ENTER key again to clear the selected data.

## Chapter 6 Trouble Shooting

- Proceed as follows for a quick detection of common faults.
- Consult your Rich Electric dealer if the fault cannot be resolved.

Problem or Error message	Cause	Solution
<div style="border: 1px solid black; padding: 5px; text-align: center;"> <b>ERROR!!!</b>            High Input Voltage         </div>	When the Wind Turbine voltage is higher than 240VDC for WindStar MPPT Chargers, the battery charging stops.	Make sure the Wind Turbine voltage is within the rated voltage range.  Make sure the diversion load is good.
<div style="border: 1px solid black; padding: 5px; text-align: center;"> <b>ERROR!!!</b>            WindStar Over-Temp.         </div>	The ambient temperature is too high and it causes the over temperature of heatsink.	Place the WindStar MPPT unit in a cool and well-ventilated room.
<div style="border: 1px solid black; padding: 5px; text-align: center;"> <b>ERROR!!!</b>            Battery Over-Temp.         </div>	The battery temperature is detected too high by the Battery Temperature Sensor (BTS-3).	Check the battery condition and place the battery bank in an well-ventilated room.
<div style="border: 1px solid black; padding: 5px; text-align: center;"> <b>ERROR!!!</b>            Parallel COM Failed         </div>	The communication failure between Master and Slave units or between Slave and Slave units has occurred.	Check the connecting cables between Master and Slave units or the cables among Slaves.