

## Setting up the Auto Start Generator function on the SuperCombi and CombiPlus

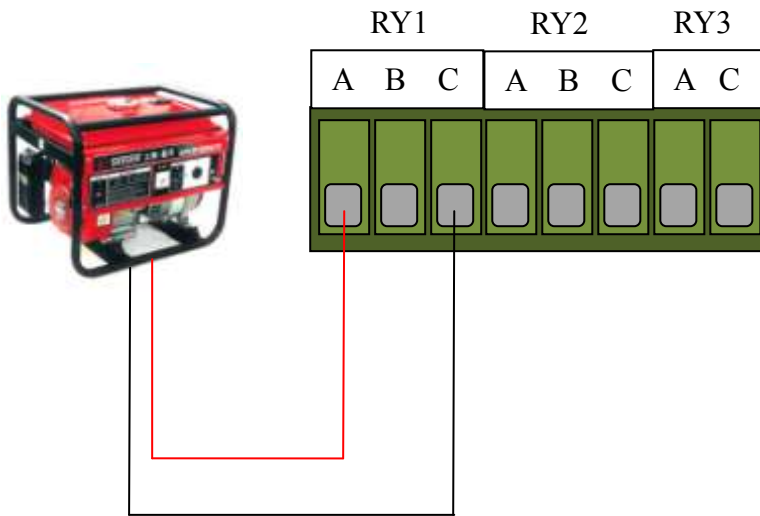

### **KEY**

RY1 = Relay No.1

RY2 = Relay No.2

RY3 = Relay No.3

A = Normally Open Contact

B = Normally Closed Contact

C = Common

Note: Switching is made between connections C "Common" & A-B. When in the "Off" position, C&A are NOT connected, but C&B are connected. You can change the state of the relay in setting E7-01 "Invert Switch". Relay no3 only has a C&A contact.

Note: Most Electric Start Generators these days offer a simple 2-wire connection for remote start applications. The way it works is when the 2-wires are joined together the generators will start and continue to run while ever the 2-wires are connected. Once disconnected the generator will stop. Note: this is NOT the start wire for the starter motor. If your generator does not support this feature please contact your generator manufacture. Or contact us for more options.

**Starting the Generator when the Batteries are LOW or if the AC Load is too large for the inverter.**

### *E Group (Auxiliary Relay No.1) For Generator Starting*

#### E1 Group (Setting Aux-Relay 1 ON Condition)

**E1-01: LOAD Higher than ? Amps**

**E1-02: LOAD Higher for ? sec**

**Main Menu>Programming>ENT>Aux-Relay>ENT**

- Use these settings to switch the Aux-Relay 1 ON. When the actual AC OUT load is above a certain value (E1-01) for a certain time (E1-02).
- The corresponding Aux-Relay 1 OFF condition is
  - E2-01: Load Lower than ? Amps and
  - E2-02: Load Lower for ? sec.

※ Note: If setting E1-02=0 sec (Initial setting). Then the E1-01 is ignored.

※ Note: If setting E2-02=0 sec (Initial setting). Then the E2-01 is ignored.

**E1-03: Udc Lower than ? Voltage**

**E1-04: Udc Lower for ? sec**

**Main Menu>Programming>ENT>Aux-Relay>ENT**

- Use these settings to switch the Aux-Relay 1 ON. When battery voltage becomes lower than a certain limit (E1-03) for a certain time (E1-04).
- ※ Note: If E1-04=0 sec (Initial setting), then E1-03 is ignored.

## E2 Group (Setting Aux-Relay 1 OFF Condition)

**E2-01: Load Lower than ? Amps**

**E2-02: Load Lower for ? sec**

### ***Main Menu>Programming>ENT>Aux-Relay>ENT***

- Use these settings to switch Aux-Relay 1 OFF. When the actual AC OUT Load is below a certain value (E2-01) for a certain time (E2-02).
  - The corresponding Aux-Relay ON condition is  
E1-01: Load Higher than ? Amps and  
E1-02: Load Higher for ? sec.
- ※ Note: If setting E2-02 (E1-02)=0 sec (Initial setting), then the E2-01 (E1-01) is ignored.

**E2-05: Udc Higher than ? Voltage**

**E2-06: Udc Higher for ? sec**

### ***Main Menu>Programming>ENT>Aux-Relay>ENT***

- Use these settings to switch off the Aux-Relay 1 when battery voltage becomes higher than a certain limit (E2-05) for a certain time (E2-06)
- ※ Note: If E2-06=0 sec (Initial setting), then E2-05 is ignored.

## *Example for Auto Start function on a typical installation:*

### **SETTINGS**

#### **Generator will Start:**

**E1-01: LOAD Higher than ? 13.0 Amps (3000W inverter) 6.5 Amps (1500W inverter)**

**E1-02: LOAD Higher for ? 1sec**

**(1 sec is normally recommended start the Generator Quickly in Hi Load situations,**

**Note: If your generator starts unexpectedly due to AC surges increase to 2 sec.**

**E1-03: Udc Lower than ? 12V (12V System) 24V (24V System)**

**E1-04: Udc Lower for ? 20sec**

#### **Generator will Stop:**

**E2-01: Load Lower than ? 6.5Amps (3000W System) 3.5Amps (1500W System)**

**E2-02: Load Lower for ? 30sec**

**E2-05: Udc Higher than ? 14V (12V System) 28V (24V System)**

**E2-06: Udc Higher for ? 240sec**

The above setting will start your generator when the AC load is greater than 13.0 Amps (approx 3000Watts) or 6.5 Amps (approx 1500Watts), for longer than “1” second.  
OR if the battery voltage goes bellow 12V /24V for longer than “20” seconds.

The generator will then switch OFF when the battery voltage is greater than 14V/28V for longer than “240” seconds.

AND if the AC load is reduced bellow 6.5A (approx 1500w) /  
3.5A (approx 800W) for longer than “30” seconds.

**NOTE: You need to Activate the Relay**

E7 Group (Aux-Relay 1 Option)

**E7-01: Aux-Relay 1 Usage Select**

**Main Menu>Programming>ENT>Aux-Relay>ENT**

Setting	Function
E7-01=0 (Initial setting)	Auxiliary Relay 1 is not allowed to be active (Idle). <b>NOT USED</b>
E7-01=1	Auxiliary Relay 1 is allowed to be active.

**E7-02: Aux-Relay 1 Invert Select**

**Main Menu>Programming>ENT>Aux-Relay>ENT**

Setting	Function
E7-02=0 (Initial setting)	Auxiliary Relay 1 is normal.
E7-02=1	Auxiliary Relay 1 is Invert switch and that is ON becomes off and OFF becomes ON.

- This is used to invert the Aux-Relay 1 So ON becomes OFF and OFF becomes ON. In the program, the labels are adapted to reflect this inversion.

**E7-03: Aux1 not Switch Off Time (Aux-Relay 1 does not switch off with certain period)**

**Main Menu>Programming>ENT>Aux-Relay>ENT**

- Use constant E7-03 to determine the minimum ON time.
  - The Aux-Relay 1 will not be switched off within the time specified here measured from the moment that all on condition are inactive.
- ※ Note: OFF conditions with a delay of 0 minute, ignore this setting.

E7-03 is Used to set a MIN run time for your generator.

For example if the AC load was to large for the inverter and the generator was started the max length of time it would run for after the load dropped bellow E2-01=6.5A would be 3 minutes (240 sec) set by E2-02=240sec.

If we would like to run the generator to run for longer than this we can use E7-03 “don’t switch off time” to increase the minimum run time.

This is also good for getting some charge into the batteries, by setting the generator to run for say 5-10min before turning off.

We would recommend this be set to no shorter than 3 minutes.

There are other options to start and stop the generator, this option below that will allow the batteries to basically be more or less fully charged then stop the generator, rather than using a set voltage. Be careful with this function as if you have a large battery bank the generator maybe running for an extended period before the batteries are charged, and you may NOT wish have the batteries fully charged anyway as you might prefer the solar panels to do most of the work....

**E2-09: Charge finished for ? Min (When E2-09=0, ignore this setting)**

***Main Menu>Programming>ENT>Aux-Relay>ENT***

- This condition becomes active when the charge bulk phase is finished for a certain time (E2-09).
- This is useful when the Aux-Relay 1 is used to start a generator. Once started, one might want to keep the generator on until the batteries are more or less charged.

**SETTINGS**

**Generator will Start:**

**E1-01: LOAD Higher than ? 13.0 Amps (3000W inverter) 6.5 Amps (1500W inverter)**

**E1-02: LOAD Higher for ? 1sec**

**(1 sec is normally recommended start the Generator Quickly in Hi Load situations,**

**Note: If your generator starts unexpectedly due to AC surges, increase to 2 sec.**

**E1-03: Udc Lower than ? 12V (12V System) 24V (24V System)**

**E1-04: Udc Lower for ? 20sec**

**Generator will Stop:**

**E2-01: Load Lower than ? 6.5Amps (3000W System) 3.5Amps (1500W System)**

**E2-02: Load Lower for ? 30sec**

**E2-09: Charge finished for ? 5 Min**

The above setting will start your generator when the AC load is greater than 13.0 Amps (approx 3000Watts) or 6.5 Amps (approx 1500Watts), for longer than "1" second.  
OR if the battery voltage goes below 12V /24V for longer than "20" seconds.

The generator will then switch OFF when the batteries have been more or less charged for longer than "5" minutes.

AND if the AC load is reduced below 6.5A (approx 1500w) /  
3.5A (approx 800W) for longer than "30" seconds.

## Using Timers to Control the Generator

If you would also like to start and stop the generator at a set time you have TWO 2x timers. We suggest you use a separate relay when using timers so to interfere with your other settings. In this case we are using Relay No.2

The timer can also be used to NOT ALLOW the generator to start if it was to receive a signal during the night to start the generator due to a flat battery. So you can set up windows that the generator is allowed to operate. Eg don't operate the generator between 10pm and 7am.

Important: You MUST set the clock for the timers to work!

### RELAY No.2 Timer Setup

#### **E3-19: When Sys-Time at T1**

##### ***Main Menu>Programming>ENT>Aux-Relay>ENT***

- Use constant E3-19 to switch Aux-Relay 1 ON. When the system time has reached the first set of time specified by E3-19, Aux-Relay 1 will be switched ON.  
Note: If E3-19=00:00, then E3-19 is ignored.

#### **E3-20: When Sys-Time at T2**

##### ***Main Menu>Programming>ENT>Aux-Relay>ENT***

- Use constant E3-20 to switch Aux-Relay 1 ON. When the system time has reached the second set of time specified by E3-20, Aux-Relay 1 will be switched ON.  
Note: If E3-20=00:00, then E3-19 is ignored.

#### **E4-20: When Sys-Time at T1**

##### ***Main Menu>Programming>ENT>Aux-Relay>ENT***

- Use constant E4-20 to switch Aux-Relay 1 OFF. When the system time has reached the first set of time specified by E4-20, Aux-Relay 1 will be switched OFF.  
Note: If E4-20=00:00, then E4-20 is ignored.

#### **E4-21: When Sys-Time at T2**

##### ***Main Menu>Programming>ENT>Aux-Relay>ENT***

- Use constant E4-21 to switch Aux-Relay 1 OFF. When the system time has reached the second set of time specified by E4-21, Aux-Relay 1 will be switched OFF.  
Note: If E4-21=00:00, then E4-21 is ignored.

**NOTE: You need to Activate the Relay E8-01 = 1 "Use Relay"**

**Using Timers to Control the Generator (NOT to start during set period of time)**

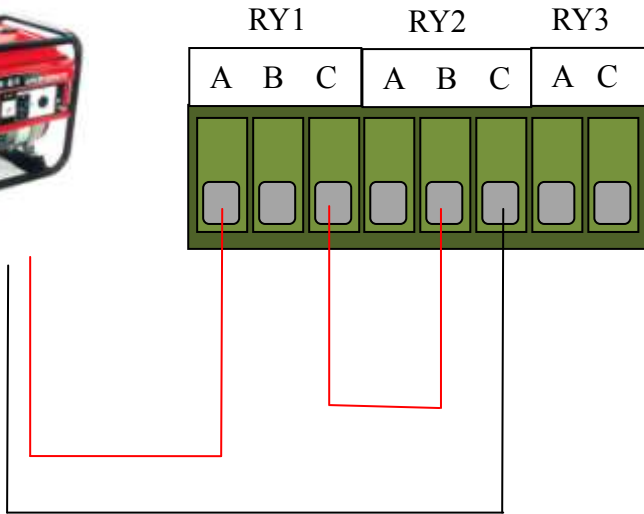

**KEY**

- RY1 = Relay No.1
- RY2 = Relay No.2
- RY3 = Relay No.3
- A = Normally Open Contact
- B = Normally Closed Contact
- C = Common

Note: Switching is made between connections C "Common" & A-B. When in the "Off" position, C&A are NOT connected, but C&B are connected. You can change the state of the relay in setting E7-01 "Invert Switch". Relay no3 only has a C&A contact.

Timer set On: E3-19 = 10pm (22:00) & Off: E4-20 = 7am (07:00)

**Using Timers to Control the Generator (Generator can only start between the set times)**

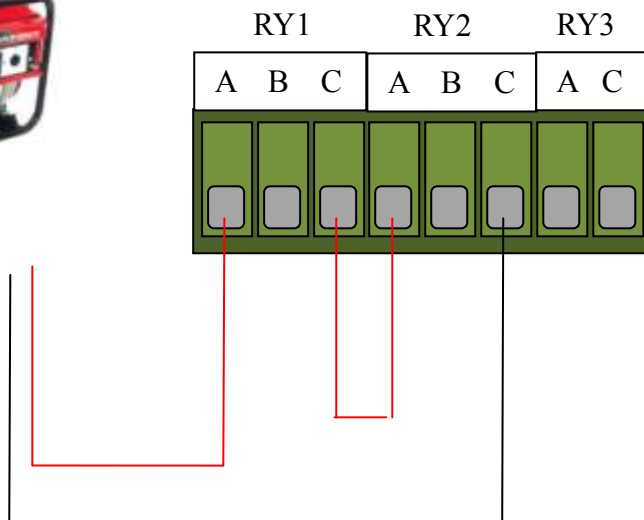

**KEY**

- RY1 = Relay No.1
- RY2 = Relay No.2
- RY3 = Relay No.3
- A = Normally Open Contact
- B = Normally Closed Contact
- C = Common

Note: Switching is made between connections C "Common" & A-B. When in the "Off" position, C&A are NOT connected, but C&B are connected. You can change the state of the relay in setting E7-01 "Invert Switch". Relay no3 only has a C&A contact.

Timer set On: E3-19 = 7am (07:00) & Off: E4-20 = 10pm (22:00)

NOTE: The wire Jumper between pins relay RY1 PIN C & relay RY2 PIN A

**Using Timers to Control the Generator (Star at a set time and stop at a set time)**

Timer set to Automatically Start the Generator regardless of a low battery or AC load,  
Timer T1 On: E3-19 = 7am (07:00) & Off: E4-20 = 8am (08:00)  
Timer T2 On: E3-20 = 6pm (18:00) & Off: E4-21 = 7pm (19:00)

This is used to run the generator during breakfast and dinner while Ac appliances are being used such as Jug, microwave etc. The generator is used to charge the batteries and supply power to the appliances during this time.

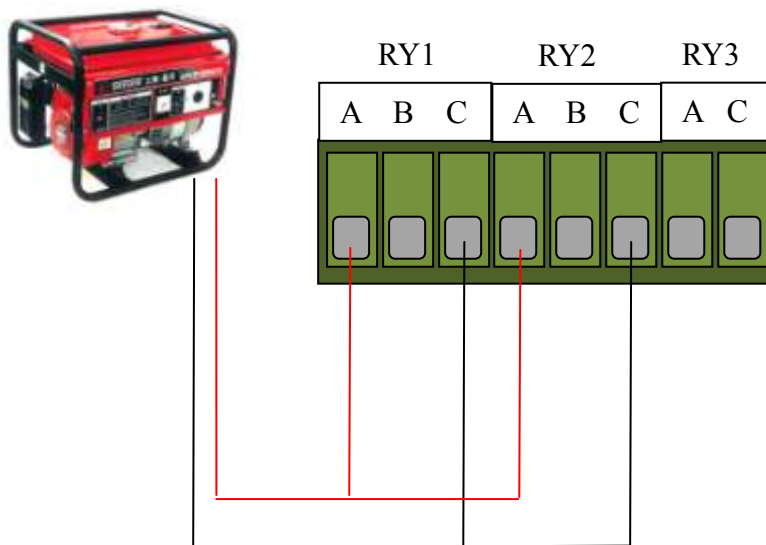

**KEY**

RY1 = Relay No.1  
RY2 = Relay No.2  
RY3 = Relay No.3  
A = Normally Open Contact  
B = Normally Closed Contact  
C = Common

Note: Switching is made between connections C "Common" & A-B  
When in the "Off" position, C&A are NOT connected, but C&B are connected.  
You can change the state of the relay in setting E7-01 "Invert Switch".  
Relay no3 only has a C&A contact.

Note: Most Electric Start Generators these days offer a simple 2-wire connection for remote start applications. The way it works is when the 2-wires are joined together the generators will start and continue to run while ever the 2-wires are connected. Once disconnected the generator will stop. Note: this is NOT the start wire for the starter motor. If your generator does not support this feature please contact you generator manufacture. Or contact us for more options.

**WARNING**

The Relay contacts are rated at 4AMPS Make sure you use fuse protection.  
If you require higher current use an external relay.