

# ***Invertek***<sup>®</sup>

## **Battery Management Control System**

**DC-SW-140 & DC-SW-140C**

**DC-SW-70 & DC-SW-70C**



# **USER MANUAL**



# Table of CONTENTS

---

|  |           |
|--|-----------|
| <b>Introduction.....</b>   | <b>4</b>  |
| <b>Features.....</b>   | <b>4</b>  |
| <b>Specifications .....</b>  | <b>5</b>  |
| <b>Dimensions.....</b>   | <b>5</b>  |
| <br>   |           |
| <b>Chapter 1 About "Battery Management Control System" .....</b>                     | <b>6</b>  |
| <b>1.1 DC/DC Charger (Battery to Battery Charging System) .....</b>                  | <b>6</b>  |
| <b>1.2 Charging from Start Battery to House Batteries .....</b>                      | <b>6</b>  |
| <b>1.3 Charging from House Batteries to Starter Battery .....</b>                    | <b>7</b>  |
| <b>1.4 Minimum Switch ON Time: DC/DC Charge Mode.....</b>                            | <b>7</b>  |
| <b>1.5 Manual Override: DC/DC Charger Mode .....</b>                                 | <b>7</b>  |
| <b>1.6 Over load Current Protection (Electronic Circuit Breaker: DC/DC .....</b>     | <b>7</b>  |
| <b>1.7 Normal Cut Out Current: DC/DC .....</b>                                       | <b>8</b>  |
| <b>1.8 Current Trip Mode: Automatic Reset or Manual Reset: DC/DC.....</b>            | <b>8</b>  |
| <b>1.9 DC Load Control Switch: Low Voltage protection .....</b>                      | <b>9</b>  |
| <b>1.10 DC Load Control Switch: Over Voltage protection .....</b>                    | <b>9</b>  |
| <b>1.11 DC Load Control Switch: Timer Function.....</b>                              | <b>9</b>  |
| <b>1.12 Manual Override: DC Load.....</b>  | <b>9</b>  |
| <b>1.13 Over load Current Protection (Electronic Circuit Breaker): DC Load .....</b> | <b>9</b>  |
| <b>1.14 Normal Cut Out Current: DC Load .....</b>                                    | <b>10</b> |
| <b>1.15 Current Trip Mode: Automatic Reset or Manual Reset: DC Load.....</b>         | <b>10</b> |
| <b>1.16 Multi-Control Operation: .....</b>   | <b>10</b> |
| <b>1.17 Connection to SuperCombi:.....</b>   | <b>11</b> |
| <br>   |           |
| <b>Chapter 2 Installation.....</b>   | <b>12</b> |
| <b>2.1 Box Contents.....</b>   | <b>12</b> |
| <b>2.2 Location .....</b>  | <b>12</b> |
| <b>2.3 Requirements.....</b>   | <b>13</b> |
| <b>2.4 Connection of Battery Cables .....</b>  | <b>13</b> |
| <b>2.5 Battery Cable Sizing chart .....</b>  | <b>14</b> |
| <b>2.6 Cabling Schematic Layout (DC/DC Battery Charger).....</b>                     | <b>15</b> |
| <b>2.7 Cabling Schematic Layout (DC Load Controller).....</b>                        | <b>15</b> |
| <b>2.8 Cabling Schematic Layout (Connection to SuperCombi®).....</b>                 | <b>15</b> |

|  |              |
|--|--------------|
| <b>Chapter 3 Display .....</b>                 | <b>.....</b> |
| <b>3.1 Front Panel Button Operations .....</b> | <b>16</b>    |
| <b>3.2 Main Menu .....</b>                     | <b>17</b>    |
| <br>   |              |
| <b>Chapter 4 Programming .....</b>             | <b>.....</b> |
| <b>4.1 A Group (Initialize).....</b>           | <b>22</b>    |
| <b>4.2 B Group (General).....</b>              | <b>24</b>    |
| <b>4.3 G Group (DC/DC Charger) .....</b>       | <b>25</b>    |
| <b>4.4 H Group (DC Load).....</b>              | <b>29</b>    |
| <b>4.5 O Group (Operator) .....</b>            | <b>32</b>    |
| <b>4.6 P Group (Communication).....</b>        | <b>34</b>    |
| <br>   |              |
| <b>Chapter 5 Constants .....</b>               | <b>.....</b> |
| <b>5.1 Constants List.....</b>                 | <b>35</b>    |
| <b>5.2 Constants Voltage Chart.....</b>        | <b>40</b>    |





# Battery Management Control System

*For use with SuperCombi® as:*  
**DC Load Controller / DC Generator input.**

**Or**

For use as a Standalone unit:  
**DC Load Controller**  
**Low Voltage disconnect re-connect with twin timer functions**

**DC/DC Charger**  
**Battery to Battery Charge Controller**

## *Features:*

---

- **Intelligent Battery Power Management Control System**
- **Bi-Directional charging: Start Battery to House Battery and House battery to Start Battery.**
- **Two DC Load control Timers**
- **Over Voltage protection**
- **DC Load control: Low voltage disconnect**
- **Fully Programmable settings**  
**Large LCD display with easy to use Menu**
- **Multi-Control Operation**
- **DC Over Current protection (Electronic Circuit Breaker)\*.**

*\*Note: This function is Available only on the DC-SW-140C & DC-SW-70C, Current is not measured on the DC-SW-140 & DC-SW-70.Models*

## Specifications

| Model                      | DC-SW-140                       | DC-SW-70       | DC-SW-140C      | DC-SW-70C      |
|----------------------------|---------------------------------|----------------|-----------------|----------------|
| Rated Amps<br>Continuous   | 100Amp<br>12VDC                 | 50Amp<br>12VDC | 100Amp<br>12VDC | 50Amp<br>12VDC |
|                            | 70Amp<br>24VDC                  | 35Amp<br>24VDC | 70Amp<br>24VDC  | 35Amp<br>24VDC |
| Rated Amps<br>Intermittent | 140Amp<br>12VDC                 | 70Amp<br>12VDC | 140Amp<br>12VDC | 70Amp<br>12VDC |
|                            | 100Amp<br>24VDC                 | 50Amp<br>24VDC | 100Amp<br>24VDC | 50Amp<br>24VDC |
| Operation<br>Voltage       | 9VDC~35VDC                      |                |                 |                |
| Current<br>Monitor         | NO                              | NO             | YES             | YES            |
| Over Voltage<br>Protection | YES                             | YES            | YES             | YES            |
| Dimensions                 | (W) 111mm x (H) 90mm x (D) 58mm |                |                 |                |

## Dimensions

UNIT : mm



UNIT : mm

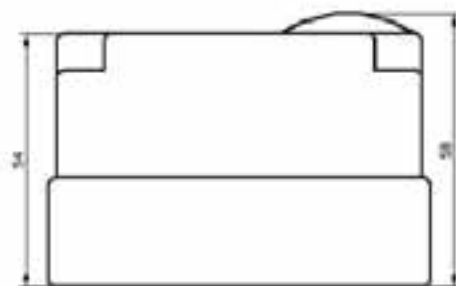

## *About Your*

### *Battery Management Control System*

---

#### **1.1 DC/DC Charger (Battery to Battery Charging System)**

The DC/DC Charger (battery to battery) controller is designed to allow charging from the engine starter battery to the house battery bank. This will also allow the start battery to be recharged if the house battery bank is being charged from a solar, wind or from mains charger, once the house batteries have recharged the set battery voltage the DC controller will automatically connect the start battery allowing the solar panels or other charging device to also charge the start battery.

G1-01 will enable the DC controller into Batt to Batt charging mode, when connected to the SuperCombi the Battery Management Control System will be activated as a DC Generator input device.

### *Bi Directional Charging System*

---

#### **1.2 Charging from Start Battery to House Batteries:**

This allows the engines charging system to charge the house batteries and the start battery. Once the start battery is full charged set by constant G1-02 (Full Voltage) and for longer than G1-03 (Sec) the Battery Management Control System will allow the engine to start charging the house batteries. This is done by connecting the start battery to house battery once the start battery has reached full charge voltage programmed into the unit. If the start battery voltage drops below the set voltage G1-04 for longer than G1-05 (Sec) the house batteries are disconnected allowing for full charge to start battery only.

The Starter Battery Full or cut in Voltage is adjusted by G1-02 and time is set by G1-03.

Cut out voltage or Starter Low Voltage is adjusted by G1-04 and time by G1-05 (sec)

Once the engine has started and the and the starter battery has reached the set voltage G1-02 for set time G1-03 the DC GEN Switch will connect to the house batteries to allow recharging from the engine. If the Starter battery voltage drops below G1-04 for longer than the set time G1-05 then the house batteries will be disconnected.

### **1.3 Charging from House Batteries to Starter Battery:**

Charging the starter battery from AC mains or renewable energy device such as wind or solar.

If the start battery is not being charged from the engine and the house batteries are fully charged (Higher than G1-06 for G1-07 time) then the Battery Management Control System will allow the house batteries to recharge the start battery.

This is very useful when combined with the SuperCombi inverter. If the system was installed into a larger boat with two DC-SW modules, (Battery Management Control Systems) this will allow both the Port and Starboard engines starter batteries to be recharged from the house bank via Solar, wind or from mains AC Charger.

Once the house battery has been fully recharged the excess power generated from the solar or wind, even the AC mains charger can be feed into the start batteries.

If the house battery voltage drops (lower than G1-08 for G1-09 time) then the start batteries will be disconnected allowing for maximum charging to take place on the house battery bank.

G1-06 adjusts the House batteries charged voltage; this allows the starter battery to be connected to the house bank.

G1-07 adjust the time, i.e. The house battery banks voltage must be higher than G1-06 for longer than time set in G1-07

### **1.4 Minimum Switch ON Time: DC/DC Charge Mode**

G1-12 adjusts the minimum ON time. E.g. if the Switch was activated when the start battery is higher than G1-02 for longer than G1-03, then the starter battery voltage falls below G1-04 for longer than G1-05, the switch will still remain ON for min of the set time set by constant G1-12 regardless of the starter battery voltage.

### **1.5 Manual Override: DC/DC Charge Mode**

G1-13 Over ride time. This feature can be used to test the charging system and can also be used for jump starting the starter battery. If for some reason the starter battery becomes flat, you can select the override feature to connect the house batteries to the starter battery. It is suggested that once you have selected the override you wait for 30 sec before trying to start your engine. When the manual override B1-03 is activated G1-13 adjusts the time the two batteries will be manually connected together regardless of any voltages.

### **1.6 Over load Current Protection (Electronic Circuit Breaker): DC/DC**

Constants G1-14 and G1-15 adjust the max current allowed through the DC /DC Charger.

G1-14 adjusts the MAX Surge Trip Current through the device. Once the current passing through the switch has reached this setting both batteries will be instantly disconnected from each other.

*\*NOTE: This function is Available only on the DC-SW-140C & DC-SW-70C, Current is not measured on the DC-SW-140 & DC-SW-70.Models*

## **1.7 Normal Cut Out Current: DC/DC**

G1-15 adjusts the normal maximum current allowed through the DC/DC Charger.

The normal current is the maximum continuous current setting.

G1-16 adjusts the time before the switch will discounted once the normal current has been reached. For example if G1-15 (Normal Cut Out Current) was set to 30amps and G1-16 (Normal Current trip Time) was set to 10 sec the switch will trip once the current has reached (G1-15) 30 amps for longer than (G1-16) 10 seconds.

G1-14 Surge current will trip instantly and is not affected by G1-16. For example if G1-14 was set to 50 amps and G1-15 was set to 30amps and G1-16 was set to 10 sec. As soon as the current reached (G1-14) 50 amps the switch would disconnect (trip).

*\*NOTE: This function is Available only on the DC-SW-140C & DC-SW-70C, Current is not measured on the DC-SW-140 & DC-SW-70.Models*

## **1.8 Current Trip Mode: Automatic Reset or Manual Reset: DC/DC**

G1-17 setting allows for Automatic or manual reset of the G1-14 and G1-15 tripping Currents. Automatic mode will reconnect after 1 min then a attempt to reconnect the switch a maximum of 3 times. Then the switch will need to be manually reset.

Manual mode: Once the switch has tripped from over current the switch will remain discontented until manually reset.

*\*NOTE: This function is Available only on the DC-SW-140C & DC-SW-70C, Current is not measured on the DC-SW-140 & DC-SW-70.Models*

## ***DC Load Controller***

---

### **1.9 DC Load Control Switch: Low Voltage protection**

The Battery Management Control System can also be used as a DC Load controller. By monitor the battery voltage the system can protect against flat or low batteries. Once the battery level reaches a crucial low level set by H1-02 for longer than the set time H1-03 the DC Load will be automatically disconnected from the battery. Once the battery has reached a safe level again, set by H1-04 for longer than the set time H1-05 then the load will be reconnected to the battery.

### **1.10 DC Load Control Switch: Over Voltage protection**

H1-06 setting will protect the system from over voltage. H1-06 adjusts the MAX allowable voltage through the switch. This is very useful to protect the DC Loads against overcharging from a malfunctioning charging system or voltage spike from engines charging system. H1-07 adjusts the safe reconnect voltage for the switch.

### **1.11 DC Load Control Switch: Timer Function**

There is TWO timers built into the system, these allow for the DC Loads to be switch ON and OFF at a set time. H1-08 to H1-11 are used to set the times.  
H1-08 Timer 1, ON time and H1-09 Timer 1, OFF time.  
H1-10 Timer 2, ON time and H1-11 Timer 2, OFF time.

### **1.12 Manual Override: DC Load**

H1-12 manual over timer allows for manual over ride of the low voltage disconnect reconnect function. If the battery voltage falls below the set cut out setting, the switch can be manual over ride. The H1-12 setting adjusts the maximum time allowed for reconnection during low voltage cut out. For example if the low voltage cut out setting H1-02 was set to 10.8v and the battery voltage was 10.2v then the switch would be disconnected. When the switch is manual over ride is activated the switch will reconnect and remain on for the set time H1-12 before disconnecting. If the battery voltage has risen above the set low voltages disconnect setting H1-04 then the switch will turn on over riding the H1-12 setting.

### **1.13 Over load Current Protection (Electronic Circuit Breaker): DC Load**

Constants H1-13 and H1-14 adjust the max current allowed through the DC Load Controller.

H1-13 adjusts the MAX Surge Trip Current through the device. Once the current passing through the switch has reached this setting the Switch will disconnect instantly.

*\*NOTE: This function is Available only on the DC-SW-140C & DC-SW-70C, Current is not measured on the DC-SW-140 & DC-SW-70.Models*

### 1.14 Normal Cut Out Current: DC Load

H1-14 adjusts the normal maximum current allowed through the switch. The normal current is the maximum continuous current setting.

H1-15 adjusts the time before the switch will discounted once the normal current has been reached. For example if H1-14 (Normal Cut Out Current) was set to 30amps and H1-15 (Normal Current trip Time) was set to 10 sec the switch will trip once the current has reached (H1-14) 30 amps for longer than (H1-15) 10 seconds.

H1-13 Surge current will trip instantly and is not affected by H1-14. For example if H1-13 was set to 50 amps and H1-14 was set to 30amps and H1-15 was set to 10 sec. As soon as the current reached (H1-13) 50 amps the switch would disconnect (trip).

*\*NOTE: This function is Available only on the DC-SW-140C & DC-SW-70C, Current is not measured on the DC-SW-140 & DC-SW-70.Models*

### 1.15 Current Trip Mode: Automatic Reset or Manual Reset: DC Load

H1-16 setting allows for Automatic or manual reset of the H1-13 and H1-14 tripping Currents. Automatic mode will reconnect after 1 min then a attempt to reconnect the switch a maximum of 3 times. Then the switch will need to be manually reset.

Manual mode: Once the switch has tripped from over current the switch will remain discontented until manually reset.

*\*NOTE: This function is Available only on the DC-SW-140C & DC-SW-70C, Current is not measured on the DC-SW-140 & DC-SW-70.Models*

### 1.16 Multi-Control Operation:

Constant P1-01 setting sets the communication mode as Multi-Control Mode.

Constant P1-02 setting selects what unit is the master and what units are to act as the slave. The numbers of slaves are set by constant P1-03. A maximum of 4 slaves can be connected to the master providing a total of 5 units to be connected, allowing for multiple loads to be controlled from the Master unit. The slaves are controlled from the master unit.

*NOTE: Do NOT connect the Load outputs together; this can damage the DC-SW.*

Correct Connection

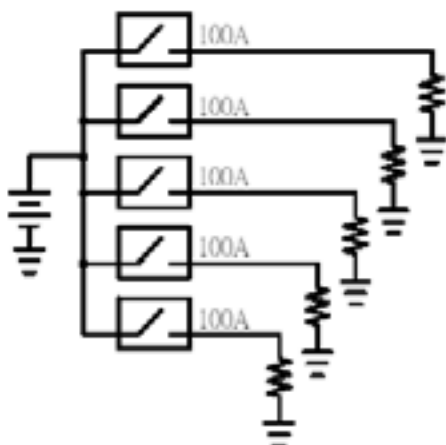

Wrong Connection

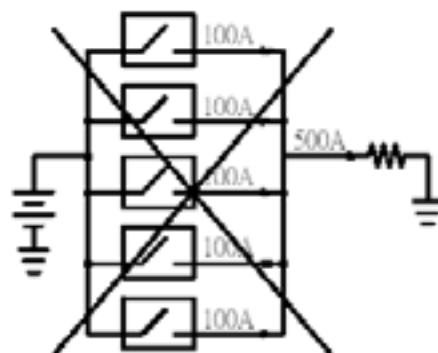

### **1.17 Connection to SuperCombi:**

For connection to SuperCombi firstly you need to select the DC-SW to be in CombiNet Mode (P1-01=2).

The CombiNet Connection Address "ID" must be set for the SuperCombi to detect the DC-SW. An ID Number must be given to the DC-SW for it to be recognized by the SuperCombi. This is done by P1-04 setting. If a number of units are to be connected to the SuperCombi a different ID Number must be given to each Switch device. For example if there were 5 units connected as a DC Switch, then the ID's given would be 1,2,3,4,5. If only two units were conned then the ID's would be set as 1,2. The SuperCombi will then automatically detect the DC-Switch when it is connected to the SuperCombi. The settings can then be controlled directly from the SuperCombi.

## 2.0 Installation

### 2.1 Box Contents

- DC-SW Battery Power Management Control System
- USER MANUAL
- Warranty Card
- 2x mounting screws

### 2.2 Location

This product must be installed in a cool and dry place that is an easy assessable location. For example in a cupboard or in a boot/storage area.



- Never position the DC-SW directly above the batteries.
- Never position the DC-SW in the engine bay of a car where extreme temperatures and water can affect the unit.

The DC-SW is recommended for wall mounting.

The front of DC-SW (battery management control system) must remain accessible after installation. Ensure the DC input cables are fitted with fuses or circuit breakers. Try and keep the distance between the product and battery to a minimum in order to minimize cable voltage losses.

A Battery Fuse or Circuit Breaker is required at all times; Never connect the DC-SW directly to the battery. The fuse or Circuit breaker should be connected as close to the battery as possible.

NOTE: The DC cabling should always be kept separated from any of the AC cabling.

## 2.3 Requirements

- Screwdrivers for mounting the DC-SW onto the wall.
- 2x battery cables ensure battery cables are correctly sized.
- Insulated box spanner for securing the DC terminal nuts.

## 2.4 Connection of Battery Cables

**NOTE:** Consult your battery manufacturer for correct battery sizing for your application.

Battery cable sizes are based on max cable length of up to 16m.  
Longer cable lengths will require large cable sizes.

Always use an insulated box spanner in order to avoid shorting the battery.  
Never short the battery cables!

For use as a DC/DC Charger (Battery to Battery)

- Connect the Start battery positive cable: the + (red) from the starter battery to the Input Post.
- Connect the House battery positive cable: the + (red) from the house battery positive to the Output Post.
- Connect the negative (-) to the battery negative of either battery. This can also be connected to ground. Note: make sure that if you are connection the negative to ground that it is a solid connection; otherwise the DC-SW will not operate correctly.
  
- NEVER connect the (+) and (-) of the battery to the input and output connection posts. This will cause internal damage.
- Secure battery nuts tightly in order to reduce the contact resistance as much as possible.

For use as a DC Load Controller (Battery to Load)

- Connect the battery positive cable: the + (red) to the Input Post.
- Connect the DC Load positive cable: the + (red) from to the Output Post.
- Connect the negative (-) to the battery negative of either battery. This can also be connected to ground. Note: make sure that if you are connection the negative to ground that it is a solid connection; otherwise the DC-SW will not operate correctly.
  
- NEVER connect the (+) and (-) of the battery to the input and output connection posts. This will cause internal damage.
- Secure battery nuts tightly in order to reduce the contact resistance as much as possible.

Battery Volt Sense (BVS) connection

- If you have long battery cable runs we recommend you use the voltage sense input. This will ensure the DC-SW will provide an accurate voltage reading. Use wires of at least 0.75mm<sup>2</sup> from the battery to the BVS input.

For more information on battery bank enclosures and installations please refer to  
AUS/NZ standards AS 2676, AS4509, AS3010 & AS4086.

For other regions, the installation and wiring should comply with relevant  
National Standards and Practices.

| <b>2.5 Battery Cable Sizing chart</b> |     |         |                |                |
|---------------------------------------|-----|---------|----------------|----------------|
| Total Cable Length                    | AMP | Voltage | Cable Size mm2 | Cable Size AWG |
| 2m                                    | 30  | 12VDC   | 5mm            | 10             |
|                                       | 50  |         | 10mm           | 8              |
|                                       | 100 |         | 16mm           | 6              |
| 4m                                    | 30  | 12VDC   | 10mm           | 8              |
|                                       | 50  |         | 16mm           | 6              |
|                                       | 100 |         | 35mm           | 2              |
| 6m                                    | 30  | 12VDC   | 16mm           | 6              |
|                                       | 50  |         | 25mm           | 4              |
|                                       | 100 |         | 50mm           | 0              |
| 8m                                    | 30  | 12VDC   | 16mm           | 6              |
|                                       | 50  |         | 35mm           | 2              |
|                                       | 100 |         | 70mm           | 2/0            |
| 10m                                   | 30  | 12VDC   | 25mm           | 4              |
|                                       | 50  |         | 35mm           | 2              |
|                                       | 100 |         | 70mm           | 2/0            |
| 12m                                   | 30  | 12VDC   | 25mm           | 4              |
|                                       | 50  |         | 50mm           | 0              |
|                                       | 100 |         | 95mm           | 3/0            |
| 14m                                   | 30  | 12VDC   | 35mm           | 2              |
|                                       | 50  |         | 70mm           | 2/0            |
|                                       | 100 |         | 95mm           | 3/0            |
| 16m                                   | 30  | 12VDC   | 35mm           | 2              |
|                                       | 50  |         | 70mm           | 2/0            |
|                                       | 100 |         | 120mm          | 4/0            |
|                                       |     |         |                |                |
| 2m                                    | 30  | 24VDC   | 2.5mm          | 14             |
|                                       | 50  |         | 4mm            | 12             |
|                                       | 70  |         | 6mm            | 10             |
| 4m                                    | 30  | 24VDC   | 4mm            | 12             |
|                                       | 50  |         | 10mm           | 8              |
|                                       | 70  |         | 10mm           | 8              |
| 6m                                    | 30  | 24VDC   | 6mm            | 10             |
|                                       | 50  |         | 10mm           | 8              |
|                                       | 70  |         | 16mm           | 6              |
| 8m                                    | 30  | 24VDC   | 10mm           | 8              |
|                                       | 50  |         | 16mm           | 6              |
|                                       | 70  |         | 25mm           | 4              |
| 10m                                   | 30  | 24VDC   | 10mm           | 8              |
|                                       | 50  |         | 25mm           | 4              |
|                                       | 70  |         | 25mm           | 4              |
| 12m                                   | 30  | 24VDC   | 16mm           | 6              |
|                                       | 50  |         | 25mm           | 4              |
|                                       | 70  |         | 35mm           | 2              |
| 14m                                   | 30  | 24VDC   | 16mm           | 6              |
|                                       | 50  |         | 25mm           | 4              |
|                                       | 70  |         | 35mm           | 2              |
| 16m                                   | 30  | 24VDC   | 16mm           | 6              |
|                                       | 50  |         | 35mm           | 2              |
|                                       | 70  |         | 50mm           | 0              |

**2.6 Cabling Schematic Layout (DC/DC Battery Charger)**

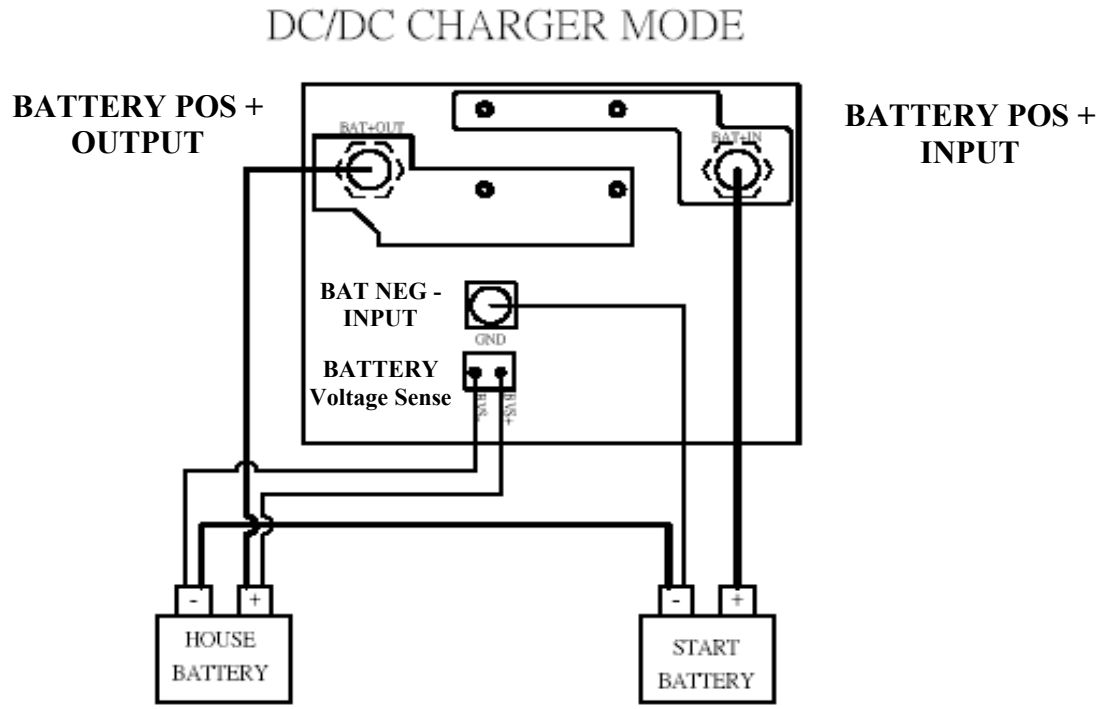

**2.7 Cabling Schematic Layout (DC Load Controller)**

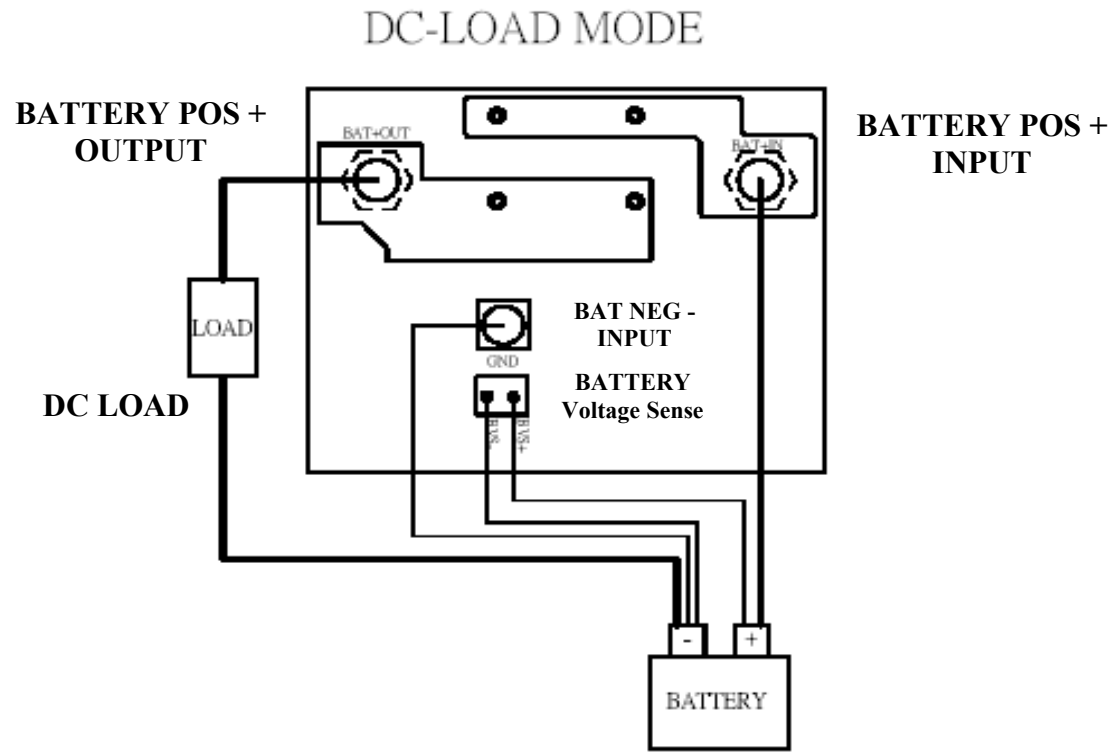



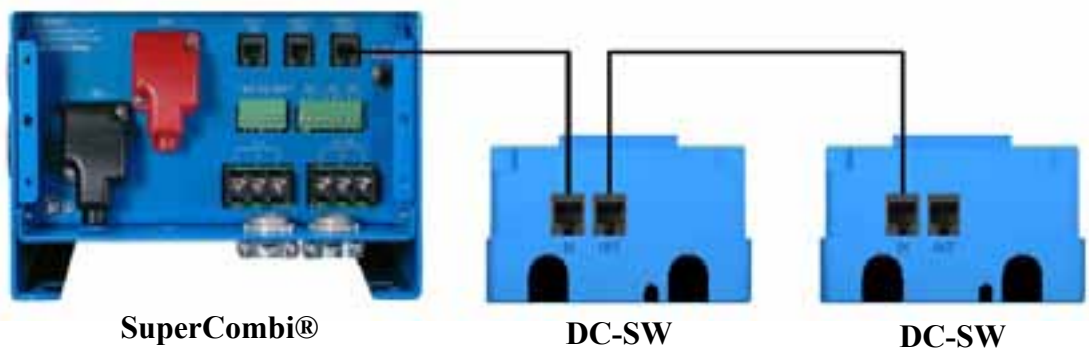

**2.8 Cabling Schematic (Connection to SuperCombi®)**







# Chapter 3 Display

## 3.1 Front Panel Button Operations

### Front Panel: Button Operations

| Push buttons   | Description  |
|--|--|
|   | Function Key to move Cursor to the left digit at Parameter Edit. |
|   | △ Increment key to edit Parameter value.                         |
|   | ▽ Decrement key to edit Parameter value.                         |
|   | Function Key to edit Data value and Data write-in key            |
|  | Function Key to return to Main Menu                              |



|                 |   |  |
|-----------------|---|--|
| DC/DC CHARGER   |  | LED indicates that the DC-SW is operating in DC/DC Charger MODE. (Battery to Battery charging)<br>Blinking: Disable DC/DC CHARGER    |
| DC LOAD CONTROL |  | LED indicates that the DC-SW is operating in DC Load MODE. (Battery to DC Load Low voltage protection).<br>Blinking: Disable DC Load |
| DC TIMER 1      |  | LED indicates that the Timer No.1 is active to control the DC Load at a set time.  |
| DC TIMER 2      |  | LED indicates that the Timer No.2 is active to control the DC Load at a set time.  |

## 3.2 Main Menu

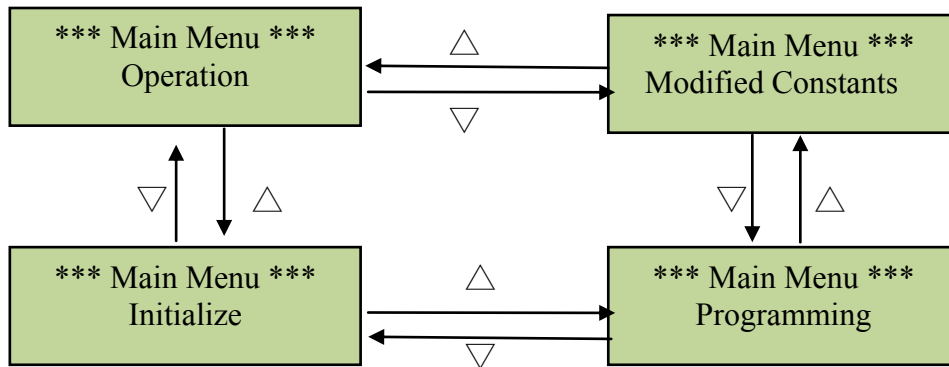

There are four options in the Main Menu:

“**Operation**”, “**Initialize**”, “**Programming**” and “**Modified Constants**”.

| Function           | Content   |
|--------------------|---|
| Operation          | Your Battery Power Management Control System can monitor Start battery voltage and current*, House battery voltage and current*, DC Load voltage and current*, Total power being charged or being used. |
| Initialize         | Operation Condition Setting Group A (Initialize) Group: Access Level setting and constants modification allowed/prohibited setting.   |
| Programming        | Constant groups to program (modify) all the constants: B (General) Group, G (DC/DC Charger) Group, H (DC Load), O (Operator) Group and Group P (Communication) Group.                                   |
| Modified Constants | Operating the read-out and modification of the constants group setting which are different from initial setting. Users can program and modify constants   |

Note: On any Menu screen, pressing “ESC” key will return you to the previous Menu.

\* This function is Available only on the DC-SW-140C & DC-SW-70C,  
Current is not measured on the DC-SW-140 & DC-SW-70.Models

## Main Menu: Operation

### “Monitor” DC/DC Charge MODE

#### U1-00: Start battery and House battery Voltage, Battery Current

**Main Menu>Operation>ENT>Monitor>ENT>**

- Use U1-00 to monitor the DC voltage from the Start Battery and the DC voltage of the House batteries. The battery value is in unit of 0.1v.
- U1-00 also monitors battery current value in unit of 1A.\*

*\*NOTE: This function is Available only on the DC-SW-140C & DC-SW-70C, Current is not measured on the DC-SW-140 & DC-SW-70.Models*

#### U1-01: DC-SW Operation Mode

**Main Menu>Operation>ENT>Monitor>ENT>**

- Use U1-01 to monitor the current control mode. (DC/DC Charger, DC Load, DC Load + Timer)

#### U1-02: DC/DC Switch Status

**Main Menu>Operation>ENT>Monitor>ENT>**

- Use U1-02 to monitor the current value status of the DC-SW.
- There are 10 digits to account for each operation status.

#### In DC/DC CHARGER Mode

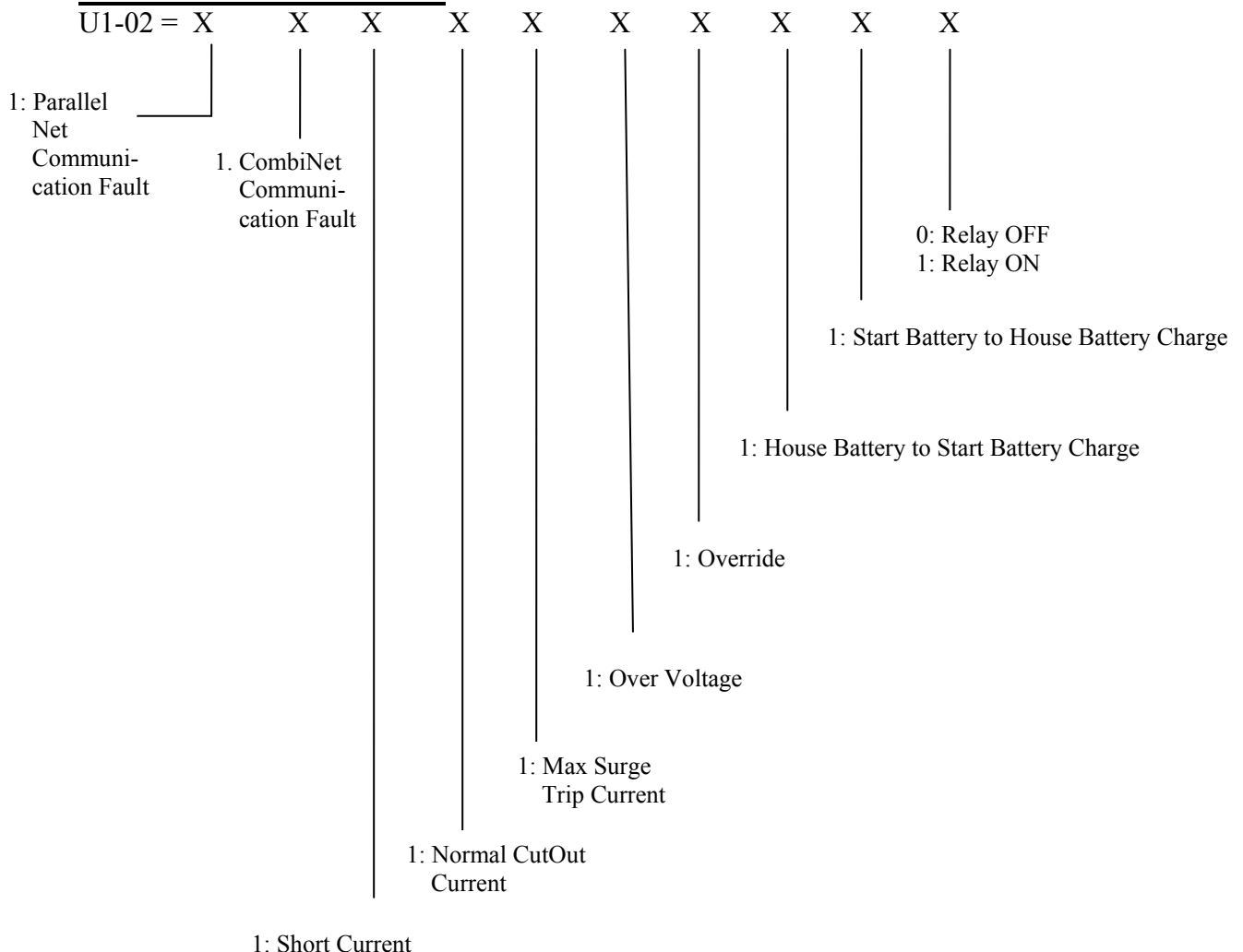



#### **U1-07: House Battery Voltage**

**Main Menu>Operation>ENT>Monitor>ENT>**

- Use constant U1-07 to monitor the House battery voltage in unit of 0.1V.

#### **U1-08: Start Charge Cur**

**Main Menu>Operation>ENT>Monitor>ENT>**

- Use constant U1-08 to monitor Start battery “real time” charging current value in unit of 1A. Eg, current being charged from the engine (starter battery) to the house battery.

*NOTE: This function is Available only on the DC-SW-140C & DC-SW-70C, Current is not measured on the DC-SW-140 & DC-SW-70.Models*

#### **U1-09: AHChargedtoHouseBatt**

**Main Menu>Operation>ENT>Monitor>ENT>**

- Use constant U1-09 to monitor Start battery charging current in Amp Hours, (Ah) value in unit of 1AH. Eg, current being charged from the engine (starter battery) to the house battery over a period of time.

*NOTE: This function is Available only on the DC-SW-140C & DC-SW-70C, Current is not measured on the DC-SW-140 & DC-SW-70.Models*

#### **U1-10: TAHChargedtoHouseBat**

**Main Menu>Operation>ENT>Monitor>ENT>**

- Use constant U1-10 to monitor Start battery Total charging current, Total Amp Hours, (Ah) value in unit of 1AH. Eg, Total amount of charge from the engine (starter battery) to the house battery.

*NOTE: This function is Available only on the DC-SW-140C & DC-SW-70C, Current is not measured on the DC-SW-140 & DC-SW-70.Models*

#### **U1-11: HouseBatt Charge Cur**

**Main Menu>Operation>ENT>Monitor>ENT>**

- Use constant U1-11 to monitor House battery “real time” charging current value in unit of 1A. Eg, current being charged from the House battery to the Starter battery.\*

#### **U1-12: AHChargedtoStartBat**

**Main Menu>Operation>ENT>Monitor>ENT>**

- Use constant U1-12 to monitor House battery charging current in Amp Hours, (Ah) value in unit of 1AH. Eg, current being charged from the House batteries to the Starter battery over a period of time.

*NOTE: This function is Available only on the DC-SW-140C & DC-SW-70C, Current is not measured on the DC-SW-140 & DC-SW-70.Models*

#### **U1-13: TAHChargedtoStartBat**

**Main Menu>Operation>ENT>Monitor>ENT>**

- Use constant U1-13 to monitor House battery Total charging current, Total Amp Hours, (Ah) value in unit of 1AH. Eg, Total amount of charge from the House battery to the Starter battery.

*NOTE: This function is Available only on the DC-SW-140C & DC-SW-70C, Current is not measured on the DC-SW-140 & DC-SW-70.Models*

## *Main Menu: Operation*

### *“Monitor” DC Load Control MODE*

---

#### **U1-14: Input Volatge**

***Main Menu>Operation>ENT>Monitor>ENT>***

- Use constant U1-14 to monitor the battery input voltage when used in DC Load Mode. The battery voltage in unit of 0.1V.

#### **U1-15: Output Voltage**

***Main Menu>Operation>ENT>Monitor>ENT>***

- Use constant U1-15 to monitor the output voltage (DC Load). The output voltage is in unit of 0.1V

#### **U1-16: DC Load Current**

***Main Menu>Operation>ENT>Monitor>ENT>***

- Use constant U1-16 to monitor the DC Load current in Amps. The value in unit of 1A

*NOTE: This function is Available only on the DC-SW-140C & DC-SW-70C, Current is not measured on the DC-SW-140 & DC-SW-70.Models*

#### **U1-17: DC Load Amp-Hours**

***Main Menu>Operation>ENT>Monitor>ENT>***

- Use constant U1-17 to monitor the DC Load being drawn from the battery in Amp Hours, (Ah) value in unit of 1AH. Eg, current being taken from the house battery to power appliances such as a lights or fridge, over a period of time.

*NOTE: This function is Available only on the DC-SW-140C & DC-SW-70C, Current is not measured on the DC-SW-140 & DC-SW-70.Models*

#### **1-18: DC Load Total AmpHours**

***Main Menu>Operation>ENT>Monitor>ENT>***

- Use constant U1-18 to monitor the Total DC Load being drawn from the battery in Amp Hours, (AH) value in unit of 1AH. Eg, The Total current that has been taken from the house battery to power appliances such as a lights or fridge.

*NOTE: This function is Available only on the DC-SW-140C & DC-SW-70C, Current is not measured on the DC-SW-140 & DC-SW-70.Models*

# Chapter 4 Programming



**Note:** Carefully read the user manual before any change is made.

## Programming Constants

### *A Group (Initialize)*

---

#### 4.1 A Group (Initialize)

##### A1-01: Access level

- Use constant A1-01 to select the user constant access level.  
This level determines which user constants can be changed and displayed.

| Setting                      | Function   |
|------------------------------|--|
| A1-01=0                      | This setting allows the “operation” and “initialize” to be changed or displayed.<br>Use this setting to prevent user constant settings from being changed. |
| A1-01=1<br>(Initial setting) | This setting allows all user constants to be changed or displayed.   |

##### A1-02: Init Parameters

- Use constant A1-02 to initialize the user constants.
- When initialized, the user constants will return to their factory preset values. You should normally record the setting of any constants that are changed from factory presets.

| Setting                      | Function   |
|------------------------------|--|
| A1-02=0<br>(Initial setting) | Returns to initialize Display without initializing any user constants. |
| A1-02=1                      | Initializes the user constants to factory settings.                    |

## **A1-03: Init Password 1**

- This constant is reserved for the factory to test and set the functions.
- Users are not allowed to set this constant.

### **Lock the constants setting (A1-01=1)**

1. Finish setting all the programmable parameters to desired values.
2. Change A1-01=0 (Operation only), factory setting is A1-01=1 (Constants set).
3. Go to A1-03 and press MENU key and UP key at the same time till A1-04 parameter occurs.
4. Enter the desired password (max. 4 digits)
5. Press UP key to leave A1-04  
Above procedure completes locking the constants setting and no more programming selection would appear. A1-01 would only display 0 (Operation only) and would not display 1 (Constants set).

### **Unlock the constants setting**

1. Enter the password in A1-03 to be exactly the same as the one earlier set in A1-04  
When the password in A1-03 matches the one earlier set in A1-04, the unlocking is completed. A1-01=1 (Constants set) would appear again for programming

## ***B Group (General)***

---

### **4.2 B Group (General)**

#### **B1-01: DC-SW Operation Sel**

***Main Menu>Programming>ENT>General>ENT>DC-SW Operation Sel >ENT***

- B1-01 is used to set the DC-SW Operation

| Setting                      | Function             |
|------------------------------|----------------------|
| B1-01=0<br>(Initial setting) | DC/DC Charger Mode   |
| B1-01=1                      | DC Load Mode         |
| B1-01=2                      | DC Load + Timer Mode |

#### **B1-02: Set battery Voltage**

***Main Menu>Programming>ENT>General>ENT>Set Battery Voltage >ENT***

- Use constant B1-02 to determine the correct battery voltage that the DC-SW will be used on.

| Setting                      | Function               |
|------------------------------|------------------------|
| B2-01=0<br>(Initial setting) | 12v DC Battery Voltage |
| B1-02=1                      | 24v DC Battery Voltage |

#### **B1-03: Manual OverRide Sel**

***Main Menu>Programming>ENT>General>ENT>Manual OverRide Sel >ENT***

- B1-03 Over ride time. This feature can be used to test the charging system and can also be used for jump starting the starter battery. If for some reason the starter battery becomes flat, you can select the override function to connect the house batteries to the starter battery. It is suggested that once you have selected the override you wait for 30 sec before trying to start your engine. When the manual override is activated G1-13 adjusts the time the two batteries will be manually connected together regardless of any voltages.

## ***G Group (DC/DC Charger)***

---

### **4.3 G Group (DC/DC Charger)**

#### **G1-01: DC/DC Switch Enable**

***Main Menu>Programming>ENT> DC/DC Charger >ENT***

- Use constant G1-01 to enable or disable the DC/DC Charging.

| Setting                      | Function                         |
|------------------------------|----------------------------------|
| G1-01=1<br>(Initial setting) | DC/DC Switch is Enabled (active) |
| G1-01=0                      | DC/DC Switch 1 is Disabled       |

#### **G1-02: Start Batt Full Volt**

***Main Menu>Programming>ENT> DC/DC Charger>ENT***

- Use constant G1-02 to adjust the DC Switch Connection voltage. When the input supply voltage higher than value set in constant G1-02, and longer than time set in constant G2-03, the DC Switch input will be connected.

#### **G1-03: Start Batt Full Time**

***Main Menu>Programming>ENT> DC/DC Charger >ENT***

- Use constant G1-03 to determine the connection detection time. Once the input voltage is higher than the value set in G1-02 and remains above G1-02, The DC Switch input will connected only after the time set in constant G1-03. Value in Seconds 0-255.
- Allowing charge from the DC Switch input supply (Starter Battery) to charge the House Batteries.

#### **G1-04: Start Batt Low Volt**

***Main Menu>Programming>ENT> DC/DC Charger >ENT***

- Use constant G1-04 to adjust the DC Generator disconnection voltage. When the input supply voltage is lower than the value set in constant G1-04, and longer than time set in constant G2-05, the DC-SW input will be disconnected.
- Disconnecting from the House Batteries from the Starter Battery.

#### **G1-05: Start Batt Low Time**

##### ***Main Menu>Programming>ENT> DC/DC Charger >ENT***

- Use constant G1-05 to determine the disconnection detection time. When the input voltage is Lower than the value set in G1-04, for longer than the time set in constant G1-05. Value in Seconds 0-255. The DC-SW input will be disconnected.

E.g. if the Start Battery Full Time (G1-03) = 120sec and Start Battery Full voltage was set to 13.3v , (G1-02)=13.3v

Once the input voltage connected DC-SW input remains above the value set in G1-02 eg 13.3v the DC-SW input will wait for the set time “Start Battery Full Time” G1-03 (20sec) before allowing the charger to be connected to the house batteries. This is useful when charging from a starter battery as it will give the starter battery time to replenish its charge first before charging the house batteries.

#### **G1-06: House Batt Full Volt**

##### ***Main Menu>Programming>ENT> DC/DC Charger >ENT***

- Use constant G1-06 to adjust the House battery “Full” voltage. This voltage will turn “ON” the reverse charging cycle. Allowing for the excess power from the house batteries to recharge the starter battery.

#### **G1-07: House Batt Full Time**

##### ***Main Menu>Programming>ENT> DC/DC Charger >ENT***

- Use constant G1-07 to determine the connection detection time. Once the house battery voltage is higher than G1-06, and longer than for the set time in constant G1-07, Value in Seconds 0-255.

Note: G1-06 & G1-07 is helpful when charging from a start battery (battery to battery).

Once the house batteries are “Full” excess power being generator from solar, wind, or even the AC Charger will allowed to be sent to the Starter batteries. Allowing for Bi-Directional charging.

#### **G1-08: House Batt Low Volt**

##### ***Main Menu>Programming>ENT> DC/DC Charger >ENT***

- Use constant G1-08 to adjust the House battery “Low” voltage. This voltage will turn “OFF” the reverse charging cycle. Allowing for the house batteries to be recharged only.

#### **G1-09: House Batt Low Time**

##### ***Main Menu>Programming>ENT> DC/DC Charger >ENT***

- Use constant G1-09 to determine the disconnect detection time. Once the house battery voltage is lower than G1-08, and longer than for the set time in constant G1-09, The DC Gen Rev Charging output will be disconnected. Value in Seconds 0-255.

#### **G1-10: Over Voltage Cut Out**

##### ***Main Menu>Programming>ENT> DC/DC Charger >ENT***

- Use constant G1-10 to adjust the DC-SW Max Input voltage. This voltage will turn “OFF” the DC-SW input to protect the house battery against over voltage.

#### **G1-11: Over Voltage Cut In**

##### ***Main Menu>Programming>ENT> DC/DC Charger >ENT***

- Use constant G1-11 to adjust the DC-SW “over voltage” reconnection Input voltage. This voltage will turn “ON” the DC-SW input again to allow charging to take place.

#### **G1-12: Min Switch ON Time**

##### ***Main Menu>Programming>ENT> DC/DC Charger >ENT***

- Use constant G1-12 to determine the minimum ON time.
- The DC-SW input will not be switched off within the time specified here measured from the moment that all on condition are inactive. Value in Seconds 0-255.

※ Note: OFF conditions with a delay of 0 Sec, ignore this setting.

#### **G1-13: Manual OverRide Time**

##### ***Main Menu>Programming>ENT> DC/DC Charger >ENT***

- Use constant G1-13 to determine the minimum “Over Ride” time.
- The DC-SW can be manually overridden. This is useful when jump starting from House batter to Starter battery or testing purpose. When in over ride mode the DC-SW will not be switched ON within the time specified time, Value in Seconds 0-255.

※ Note: OFF conditions of 0 Sec, ignore this setting.

#### **G1-14: MaxSurge Trip Current**

##### ***Main Menu>Programming>ENT> DC/DC Charger >ENT***

- Use constant G1-14 to determine the Maximum Surge “Trip” Current.
- This feature acts as **Over load Current Protection** (Electronic Circuit Breaker):
- Constants G1-14, G1-15 and G1-16 adjust the max current allowed through the DC switch.
- G1-14 adjusts the MAX Surge Trip Current through the device. Once the current passing through the switch has reached this setting the Switch will disconnect instantly.

※ Note: *This function is Available only on the DC-SW-140C & DC-SW-70C, Current is not measured on the DC-SW-140 & DC-SW-70.Models*

### G1-15: NormalCutOut Current

#### **Main Menu>Programming>ENT> DC/DC Charger >ENT**

- Use constant G1-15 to adjust the normal maximum current allowed through the switch. The normal current is the maximum continuous current setting.

※ Note: This function is Available only on the DC-SW-140C & DC-SW-70C, Current is not measured on the DC-SW-140 & DC-SW-70.Models

### G1-16: NormalCur Trip Time

#### **Main Menu>Programming>ENT> DC/DC Charger >ENT**

- Constant G1-16 adjusts the time before the switch will discounted once the normal current has been reached. For example if G1-15 (Normal Cut Out Current) was set to 30amps and G1-16 (Normal Current trip Time) was set to 10 sec the switch will trip once the current has reached (G1-15) 30 amps for longer than (G1-16) 10 seconds.
- G1-14 Surge current will trip instantly and is not affected by G1-15. For example if G1-14 was set to 50 amps and G1-15 was set to 30amps and G1-16 was set to 10 sec. As soon as the current reached (G1-14) 50 amps the switch would disconnect (trip).

※ Note: This function is Available only on the DC-SW-140C & DC-SW-70C, Current is not measured on the DC-SW-140 & DC-SW-70.Models

### G1-17: Current Trip Mode

#### **Main Menu>Programming>ENT> DC/DC Charger >ENT**

- G1-16 setting allows for Automatic or manual reset of the G1-14 Surge tripping Current & G1-15 Normal Cut out Current. Automatic mode will reconnect after 1 min then a attempt to reconnect the switch a maximum of 3 times. Then the switch will need to be manually reset.
- Manual mode: Once the switch has tripped from over current set by G1-14 and G1-15 the switch will remain discontented until manually reset.

| Setting                      | Function                      |
|------------------------------|-------------------------------|
| G1-16=1<br>(Initial setting) | Automatic is Enabled (active) |
| G1-16=0                      | Manual                        |

※ Note: This function is Available only on the DC-SW-140C & DC-SW-70C, Current is not measured on the DC-SW-140 & DC-SW-70.Models

## *H Group (DC Load)*

---

### **4.4 H Group (DC Load)**

#### **H1-01: DC Load Enable**

***Main Menu>Programming>ENT> DC Load >ENT***

| Setting                      | Function                                 |
|------------------------------|--|
| H1-01=1<br>(Initial setting) | DC Load Controller 1 is Enabled (active) |
| H1-01=0                      | DC Load Controller 1 is Disabled         |

#### **H1-02: Low Voltage Disconnect**

***Main Menu>Programming>ENT> DC Load >ENT***

- Use constant H1-02 to adjust the DC Load controller disconnection voltage. When the voltage set in constant H1-02, the DC Load controller will be disconnected.

#### **H1-03: Low Voltage for ? Sec**

***Main Menu>Programming>ENT> DC Load >ENT***

- Use constant H1-03 to determine the minimum disconnect detection time. Once the input voltage is lower than H1-02, for longer than H1-03, The DC Load controller will disconnected load to prevent the battery from being exhausted.

#### **H1-04: Reconnect Voltage**

***Main Menu>Programming>ENT> DC Load >ENT***

- Use constant H1-04 to adjust the DC controller reconnection voltage. When the voltage is above set in constant H1-04, for longer than H1-05 Sec? the DC controller will be allow the load to connect to the battery.

#### **H1-05: Reconnect for ? Sec**

***Main Menu>Programming>ENT> DC Load >ENT***

- Use constant H1-05 to determine the minimum connection detection time. Once the battery voltage is higher than H1-04, for longer than H1-05 The DC Load controller will reconnect to the load.

#### **H1-06: Over Voltage Cut Out**

***Main Menu>Programming>ENT> DC Load >ENT***

- Use constant H1-06 to adjust the DC Load Max output voltage. This voltage will turn “OFF” the DC Load output to protect the load against over voltage output.

#### **H1-07: Over Voltage Cut In**

***Main Menu>Programming>ENT> DC Load >ENT***

- Use constant H1-07 to adjust the DC Load “over voltage” reconnection Input voltage. This voltage will turn “ON” the DC Load output again to allow output supply.

#### **H1-08: Timer 1 ON Time**

***Main Menu>Programming>ENT> DC Load >ENT***

- Use constant H1-08 to adjust the DC Load Timer 1 Turn ON Time.
- The DC Load will be switched ON at this time.

#### **H1-09: Timer 1 OFF Time**

***Main Menu>Programming>ENT> DC Load >ENT***

- Use constant H1-09 to adjust the DC Load Timer 1 OFF Time.
- The DC Load will be switch OFF at this time.

#### **H1-10: Timer 2 ON Time**

***Main Menu>Programming>ENT> DC Load >ENT***

- Use constant H1-10 to adjust the DC Load Timer 2 Turn ON Time.
- The DC Load will be switched ON at this time.

#### **H1-11: Timer 2 OFF Time**

***Main Menu>Programming>ENT> DC Load >ENT***

- Use constant H1-11 to adjust the DC Load Timer 2 OFF Time.
- The DC Load will be switched OFF at this time.

#### **H1-12: Manual OverRide Time**

***Main Menu>Programming>ENT> DC Load >ENT***

- Use constant H1-12 to determine the minimum “Over Ride” time.
- The DC Load can be manually overridden. This is useful when the House battery is low and you need to operate a load for a short period of time or testing purpose. When in over ride mode the DC Load will not be switched ON within the time specified time, Value in minutes 0-59.

※ Note: OFF conditions of 0 min, ignore this setting.

### H1-13: MaxSurge Trip Current

#### Main Menu>Programming>ENT> DC/DC Charger >ENT

- Use constant H1-13 to determine the Maximum Surge “Trip” Current.
- This feature acts as **Over load Current Protection** (Electronic Circuit Breaker):
- Constants H1-13, H1-14 and H1-15 adjust the max current allowed through the DC switch.
- H1-13 adjusts the MAX Surge Trip Current through the device. Once the current passing through the switch has reached this setting the Switch will disconnect instantly.

※ Note: This function is Available only on the DC-SW-140C & DC-SW-70C, Current is not measured on the DC-SW-140 & DC-SW-70.Models

### H1-14: NormalCutOut Current

#### Main Menu>Programming>ENT> DC/DC Charger >ENT

- Use constant H1-14 to adjust the normal maximum current allowed through the switch. The normal current is the maximum continuous current setting.

※ Note: This function is Available only on the DC-SW-140C & DC-SW-70C, Current is not measured on the DC-SW-140 & DC-SW-70.Models

### H1-15: NormalCut Trip Time

#### Main Menu>Programming>ENT> DC/DC Charger >ENT

- Constant H1-15 adjusts the time before the switch will discounted once the normal current has been reached. For example if H1-14 (Normal Cut Out Current) was set to 30amps and H1-15 (Normal Current trip Time) was set to 10 sec the switch will trip once the current has reached (H1-14) 30 amps for longer than (H1-15) 10 seconds.
- H1-13 Surge current will trip instantly and is not affected by H1-14. For example if H1-13 was set to 50 amps and H1-14 was set to 30amps and H1-15 was set to 10 sec. As soon as the current reached (H1-13) 50 amps the switch would disconnect (trip).

※ Note: This function is Available only on the DC-SW-140C & DC-SW-70C, Current is not measured on the DC-SW-140 & DC-SW-70.Models

### H1-15: Current Trip Mode

#### Main Menu>Programming>ENT> DC/DC Charger >ENT

- H1-15 setting allows for Automatic or manual reset of the H1-13 Surge tripping Current & H1-14 Normal Cut out Current. Automatic mode will reconnect after 1 min then a attempt to reconnect the switch a maximum of 3 times. Then the switch will need to be manually reset.
- Manual mode: Once the switch has tripped from over current set by H1-13 and H1-14 the switch will remain discontented until manually reset.

| Setting                      | Function           |
|------------------------------|--------------------|
| H1-15=1<br>(Initial setting) | Automatic (active) |
| H1-15=0                      | Manual             |

※ Note: This function is Available only on the DC-SW-140C & DC-SW-70C, Current is not measured on the DC-SW-140 & DC-SW-70.Models

## O Group (Operator)

### 4.5 O Group (Operator)

#### O1-01: Power-On Monitor Sel

**Main Menu>Programming>ENT>Operator>ENT>**

- After power of the DC-SW is on, the monitor selections will be showed on LCD Display, U1-00 IN=xx.xV OUT=xx.xV is the initial display shown.
- All the constants in U1 Group can be programmed (U1-00~U-18).

#### O1-02: Key Idle Detect Time

**Main Menu>Programming>ENT>Operator>ENT>**

- Use constant O1-02 to set the idle time when the keyboard is not operated and once any key is pressed, the display will return to the LCD monitor selection value set in constant O1-01.

Initial Setting=180 sec, setting range: 10~600 sec.

#### O1-03: LCD Display Idle Time Set

**Main Menu>Programming>ENT>Operator>ENT>**

- When O1-03=0, Display Idle Function is disabled.
- Use constant O1-03 to set the idle time when the keypad is not operated and all the LCD Display and LED Indicators of the DC-SW entering the idle mode which only RUN/STOP indicator is active.
- Once any key on the panel is pressed, it will return to the display before Idle status.
- Initial setting=10 min, setting range: 0~60 min.

#### O1-04: Elapsed Time Reset

**Main Menu>Programming>ENT>Operator>ENT>**

- Use constant O2-02 to reset elapsed time.

#### O1-05: Elapsed Time Select

**Main Menu>Programming>ENT>Operator>ENT>**

| Setting                      | Function  |
|------------------------------|---|
| O1-05=0<br>(Initial setting) | The elapsed time started to be counted after power is on.               |
| O1-05=1                      | The elapsed time started to be counted when in operation.<br>“Run Time” |

#### **O1-06: System Time Setting**

***Main Menu>Programming>ENT>Operator>ENT>Key  
Selections>ENT>***

- Use constant O1-06 to set the system time. Format is hh:mm, “hh” is hour (0~23) and “mm” is minute (00~59).

#### **O1-07: System Date Setting**

***Main Menu>Programming>ENT>Operator>ENT>Key  
Selections>ENT>***

- Use constant O1-07 to set the system date. Format is yy-mm-dd, “yy” is year (0~99), “mm” is month (01~12), and “dd” is date (01~31).

## *P Group (Communication)*

---

### 4.6 P Group (Communication)

#### **P1-01: Communication Mode Sel**

**Main Menu>Programming>ENT> Communication >ENT**

- Use Constant P1-01 setting selects the DC-SW Mode for standalone operation or multi-control or communication to SuperCombi®

| Setting                      | Function           |
|------------------------------|--------------------|
| P1-01=0<br>(Initial setting) | Standalone         |
| P1-01=1                      | Multi-Control Mode |
| P1-01=2                      | Combi Net Mode     |

#### **P1-02: Multi-Control Mode**

**Main Menu>Programming>ENT> Communication >ENT**

- Use Constant P1-02 setting selects what unit is the master and what units are to act as the slave. The numbers of Multi-control units (slaves) are set by constant P1-03. A maximum of 4 units can be connected to the master providing a total of 5 units to be connected together. The slaves are then controlled from the master unit.

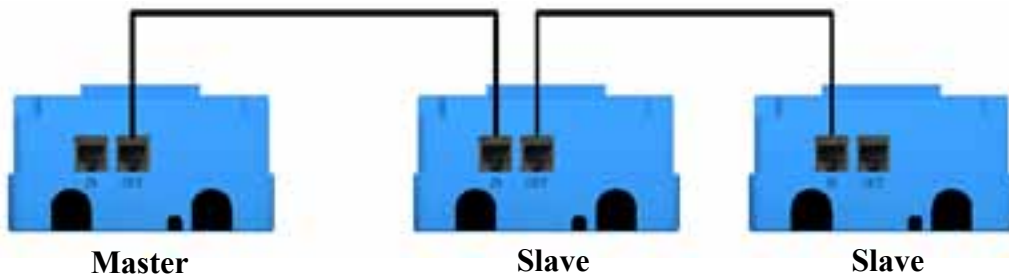

#### **P1-03: MultiCtrl Address Set**

**Main Menu>Programming>ENT> Communication >ENT**

- Use Constant P1-03 setting to select the units address, For example if there was 5 units connected together, then the ID's given would be 1,2,3,4,5. If only two unit were conned then the ID's would be set as 1,2.

#### **P1-04: CombiNet Address Set**

**Main Menu>Programming>ENT> Communication >ENT**

- Use Constant P1-04 setting to select the CombiNet address in the range of 1~5.
- An ID Number must be given to the Switch for it to be recognized by the SuperCombi.
- If a number of units are to be connected to the SuperCombi a different ID Number must be given to each DC Switch device. For example if there were 2 units connected to the SuperCombi®, then the ID's given would be 1,2. If only one unit were connected then the ID would be set as "1".

# Chapter 5 Constants list

| Constant | LCD Display   | Range        | Unit  | Factory Setting   |
|----------|---|--------------|-------|-------------------|
| U1-00    | IN=xx.xxV<br>OUT=xx.xxV<br>RELAY: OFF<br>BVS=xx.xxV | User Display |       | DC/DC<br>Charger  |
| U1-01    | DC-SW<br>Operation                                  | User Display |       | DC/DC<br>Charger  |
| U1-02    | DC/DC<br>Switch Status                              | User Display |       | DC/DC<br>Charger  |
| U1-03    | Elapsed<br>Time                                     | User Display |       | DC/DC<br>Charger  |
| U1-04    | System<br>Time                                      | User Display |       | DC/DC<br>Charger  |
| U1-05    | Software<br>Version                                 | User Display |       | DC/DC<br>Charger  |
| U1-06    | Start Battery<br>Voltage                            | User Display | 0.01V | DC/DC<br>Charger  |
| U1-07    | House Battery<br>Voltage                            | User Display | 0.01V | DC/DC<br>Charger  |
| U1-08    | Start Battery<br>Charge Current                     | User Display | 1A    | DC/DC<br>Charger* |
| U1-09    | AH Charged to<br>House Battery                      | User Display | 1AH   | DC/DC<br>Charger* |
| U1-10    | TAH Charge to<br>House Battery                      | User Display | 1A    | DC/DC<br>Charger* |
| U1-11    | House Battery<br>Charge Current                     | User Display | 1A    | DC/DC<br>Charger* |
| U1-12    | AH Charged to<br>Start Battery                      | User Display | 1AH   | DC/DC<br>Charger* |
| U1-13    | TAH Charged<br>to Start Battery                     | User Display | 1AH   | DC/DC<br>Charger* |
| U1-14    | Input Voltage                                       | User Display | 0.01V | DC Load<br>MODE   |
| U1-15    | Output Voltage                                      | User Display | 0.01V | DC Load<br>MODE   |
| U1-16    | DC Load<br>Current                                  | User Display | 1A    | DC Load<br>MODE*  |
| U1-17    | DC Load Amp<br>Hours                                | User Display | 1AH   | DC Load<br>MODE*  |
| U1-18    | DC Load Total<br>Amp Hours                          | User Display | 1AH   | DC Load<br>MODE*  |

**Notes:**

Constants with \* are available only on the DC-SW-140C & DC-SW-70C, Current is not measured on the DC-SW-140 & DC-SW-70.Models

| Constant      | LCD Display     | Range              | Unit | Factory Setting |
|---------------|-----------------|--------------------|------|-----------------|
| A1-01         | Access Level    | 0: Operation Only  | 1    | Constant Set    |
|               |                 | 1: Constant Set    |      |                 |
| A1-02         | Init Parameters | 0: No Initialize   | 1    | No Initialize   |
|               |                 | 1: Default Setting |      |                 |
| A1-03         | Password 1      | 0~9999             | 1    | 0               |
| A1-04         | Password 2      | 0~9999             | 1    | 0               |
| <i>Notes:</i> |                 |                    |      |                 |

| Constant      | LCD Display            | Range   | Unit | Factory Setting |
|---------------|------------------------|---|------|-----------------|
| B1-01         | DC-SW Operation Select | 0: DC/DC Charger<br>1: DC Load Mode<br>2: DC Load +Timer Mode | 0~2  | 0:DC/DC Charger |
| B1-02         | Set Battery Voltage    | 0:12VDC<br>1:24VDC  | 0~1  | 0: 12VDC        |
| B1-03         | Manual Over Ride       | 0: Enable<br>1: Disable                                       | 0~1  | 1: Disabled     |
| <i>Notes:</i> |                        |   |      |                 |

| Constant  | LCD Display              | Range                 | Unit       | Factory Setting |
|---|--------------------------|-----------------------|------------|-----------------|
| G1-01   | DC/DC Switch Enable      | 1:Enable<br>0:Disable | 0~1        | 1               |
| G1-02   | Start Batt Full Volt?    | 0~16V                 | 0.01V      | 13.3V           |
|   |                          | 0~32V                 |            | 26.6V           |
| G1-03   | Start Batt Full Time?    | 0~255                 | 1 sec      | 20 sec          |
| G1-04   | Start Batt Low Volt?     | 0~16V                 | 0.01V      | 12.8V           |
|   |                          | 0~32V                 |            | 25.6V           |
| G1-05   | Start Batt Low Time?     | 0~255                 | 1 sec      | 10 sec          |
| G1-06   | House Batt Full Volt?    | 0~16V                 | 0.01V      | 14.4V           |
|   |                          | 0~32V                 |            | 28.8V           |
| G1-07   | House Batt Full Time?    | 0~255                 | 1 sec      | 60sec           |
| G1-08   | House Batt Low Volt?     | 0~16V                 | 0.01V      | 13.2V           |
|   |                          | 0~32V                 |            | 26.4V           |
| G1-09   | House Batt Low Time?     | 0~255                 | 1 sec      | 20 sec          |
| G1-10   | Over Voltage Cut Out?    | 0~16V                 | 0.01V      | 15.2V           |
|   |                          | 0~32V                 |            | 30.4V           |
| G1-11   | Overvoltage Cut In?      | 0~16V                 | 0.01V      | 14.9V           |
|   |                          | 0~32V                 |            | 30.2V           |
| G1-12   | Min Switch ON Time       | 0~255                 | 1 sec      | 10 sec          |
| G1-13   | Manual OverRide Time     | 0~255                 | 1 sec      | 60 sec          |
| G1-14   | Max Surge Trip Current   | 0~140A                | 1A         | 140A*           |
|   |                          | 0~70A                 |            | 70A*            |
| G1-15   | Normal Cut Out Current   | 0~140                 | 1A         | 100A*           |
|   |                          | 0~70A                 |            | 50A*            |
| G1-16   | Normal Current Trip Time | 0~255                 | 1 Sec      | 10 Sec*         |
| G1-17   | Current Trip Mode:       |                       | Auto Reset | Auto Reset*     |
|   |                          |                       | Manual     |                 |
| <p><i>Notes:</i><br/> Constants with * are available only on the DC-SW-140C &amp; DC-SW-70C, Current is not measured on the DC-SW-140 &amp; DC-SW-70.Models</p> |                          |                       |            |                 |

| Constant | LCD Display              | Range                   | Unit       | Factory Setting |
|----------|--------------------------|-------------------------|------------|-----------------|
| H1-01    | DC Load Enable           | 0: Enable<br>1: Disable | 0~1        | 1               |
| H1-02    | Low voltage Disconnect?  | 0~16V                   | 0.01V      | 13.3V           |
|          |                          | 0~32V                   |            | 26.6V           |
| H1-03    | Low Voltage for ? sec    | 0~255                   | 1 sec      | 20 sec          |
| H1-04    | Reconnect Voltage?       | 0~16V                   | 0.01V      | 12.8V           |
|          |                          | 0~32V                   |            | 25.6V           |
| H1-05    | Reconnect for ?sec       | 0~255                   | 1 sec      | 10 sec          |
| H1-06    | Overvoltage Cut Out?     | 0~16V                   | 0.01V      | 15.2V           |
|          |                          | 0~32V                   |            | 30.4V           |
| H1-07    | Overvoltage Cut In?      | 0~16V                   | 0.01V      | 14.9V           |
|          |                          | 0~32V                   |            | 29.8V           |
| H1-08    | Timer 1 ON Time:         | Hour 0~23<br>Min 0~59   | 1          | 00:00           |
| H1-09    | Timer 1 OFF Time:        | Hour 0~23<br>Min 0~59   | 1          | 00:00           |
| H1-10    | Timer 2 ON Time:         | Hour 0~23<br>Min 0~59   | 1          | 00:00           |
| H1-11    | Timer 2 OFF Time:        | Hour 0~23<br>Min 0~59   | 1          | 00:00           |
| H1-12    | Manual Over Ride Time    | 0~59min                 | 1 min      | 5 min           |
| H1-13    | Max Surge Trip Current   | 0~140A                  | 1A         | 140A*           |
|          |                          | 0~70A                   |            | 70A*            |
| H1-14    | Normal Cut Out Current   | 0~140A                  | 1A         | 100A*           |
|          |                          | 0~70A                   |            | 50A*            |
| H1-15    | Normal Current Trip Time | 0~255                   | 1 Sec      | 10 Sec*         |
| H1-16    | Current Trip Mode:       | User Display            | Auto Reset | Auto Reset*     |
|          |                          |                         | Manual     |                 |

**Notes:**

Constants with \* are available only on the DC-SW-140C & DC-SW-70C, Current is not measured on the DC-SW-140 & DC-SW-70.Models

| Constant      | LCD Display             | Range                                    | Unit   | Factory Setting |
|---------------|-------------------------|--|--------|-----------------|
| O1-01         | Power-On Monitor Select | U1-00~U1-18                              | 1      | 0               |
| O1-02         | Key Idle Time Set       | 10~600                                   | 1 Sec  | 180Sec          |
| O1-03         | Display Idle Time Set   | 0~60                                     | 1 Min  | 10 Min          |
| O1-04         | Elapsed Time Reset      | 0~60000                                  | 1 Hour | 0               |
| O1-05         | Elapsed Time Select     | 0: Power On<br>1: Run Time               | 1      | 0: Power On     |
| O1-06         | System Time Setting     | Hour: 0~23<br>Minute: 0~59               | 1      | 00:00           |
| O1-07         | System Date Setting     | Year: 00~99<br>Month: 1~12<br>Date: 1~31 | 1      | 00:00           |
| O1-08         | Model Number            | User Display                             |        |                 |
| <i>Notes:</i> |                         |  |        |                 |

| Constant      | LCD Display               | Range                 | Unit | Factory Setting |
|---------------|---------------------------|-----------------------|------|-----------------|
| P1-01         | Communication Mode Select | 0: Standalone         | 0~2  | 0: Standalone   |
|               |                           | 1: MultiCtrl Mode     |      |                 |
|               |                           | 2: CombiNet Mode      |      |                 |
| P1-02         | Multi-Control Mode        | 0) Master<br>1) Slave | 0~1  | 0: Master       |
| P1-03         | MultiCtrl Address Set     | 1~5                   | 1    | 1               |
| P1-04         | CombiNet Address          | 1~15                  | 1    | 1               |
| <i>Notes:</i> |                           |                       |      |                 |

## 5.2 Constants Voltage Chart

| Constant<br>Volts | G1-02 "Start Batt Full" |       |                 | G1-04 "Start Batt Low" |       |                 | G1-06 "House Batt Full" |       |                 | G1-08 "House Batt Low" |       |                 |
|-------------------|-------------------------|-------|-----------------|------------------------|-------|-----------------|-------------------------|-------|-----------------|------------------------|-------|-----------------|
|                   | Range                   | Unit  | Factory Setting | Range                  | Unit  | Factory Setting | Range                   | Unit  | Factory Setting | Range                  | Unit  | Factory Setting |
| <b>12VDC</b>      | 1~16V                   | 0.01V | 13.3V           | 1~16V                  | 0.01V | 12.8V           | 1~16V                   | 0.01V | 14.4V           | 1~16V                  | 0.01V | 13.2V           |
| <b>24VDC</b>      | 2~32V                   | 0.01V | 26.6V           | 2~32V                  | 0.01V | 25.6V           | 2~32V                   | 0.01V | 28.8V           | 2~32V                  | 0.01V | 26.4V           |

| Constant<br>Volt | H1-02<br>"Low Volt Disconnect" |       |                 | H1-04<br>"Reconnect Voltage" |       |                 | H1-06<br>"Over Volt Cut Out" |       |                 | H1-07<br>"Over Volt Cut In" |       |                 |
|------------------|--------------------------------|-------|-----------------|------------------------------|-------|-----------------|------------------------------|-------|-----------------|-----------------------------|-------|-----------------|
|                  | Range                          | Unit  | Factory Setting | Range                        | Unit  | Factory Setting | Range                        | Unit  | Factory Setting | Range                       | Unit  | Factory Setting |
| <b>12VDC</b>     | 1~16V                          | 0.01V | 13.3V           | 1~16V                        | 0.01V | 12.8V           | 1~16V                        | 0.01V | 15.2V           | 1~16V                       | 0.01V | 14.9V           |
| <b>24VDC</b>     | 2~32V                          | 0.01V | 26.6V           | 2~32V                        | 0.01V | 25.6V           | 2~32V                        | 0.01V | 30.4V           | 2~32V                       | 0.01V | 29.8V           |

***NOTES:***